

20
24/25



Lista de Productos_01
Product List_01

Herramientas Manuales
Hand Tools

TRAMONTINA

TRAMONTINA

Más que números, lo que define a Tramontina es el esfuerzo permanente para mejorar cada vez más la vida de la gente. La pequeña herrería fundada por Valentin y Elisa Tramontina en 1911, en el sur de Brasil, originó un grupo que hoy cuenta con 9 unidades fabriles y mantiene la vocación centenaria de encantar con gestos sencillos.

El secreto para mantener la esencia es creer en las personas. Tramontina valora a cada uno de los más de 10 mil empleados para que le entreguen al mercado productos funcionales y con estilo, que inspiran el día a día y estimulan experiencias para generar valor y satisfacción a clientes, consumidores y comunidades.

Todo eso se traduce en los más de 22 mil artículos que llevan los valores de una marca única. Utensilios y equipos de cocina, electrodomésticos, herramientas para agricultura, jardinería, mantenimiento industrial y automovilístico, construcción civil, materiales eléctricos, muebles de madera o de plástico, además de la amplia línea de equipos dirigibles, que se fabrican para el mercado nacional y de exportación para más de 120 países.

Es en el hacer bien las cosas que se encuentran Tramontina y las personas. Actuando de forma global, la marca tiene el soporte necesario para entregar soluciones capaces de atender las necesidades de su tiempo, aliando productividad y superación de metas de desarrollo sustentable por medio del programa de gestión ambiental.

¡Mucho gusto, Tramontina!

TRAMONTINA GARIBALDI

Tramontina Garibaldi, fundada en el año de 1963, está ubicada en la ciudad Garibaldi, RS, Brasil. Hoy con 98 mil m² de área construida, esta unidad fabril cuenta con 850 empleados y produce un mix de productos destinados al mercado de herramientas manuales, en el que actúa en tres distintos segmentos.

La Línea PRO atiende principalmente a los profesionales de los sectores industrial y automotriz. La Línea Master atiende el mercado de la construcción civil. Y la Línea Hágalo Usted Mismo atiende el mercado de uso doméstico.

Los productos siguen un riguroso control de calidad y fabricación, especialmente en lo que se refiere a la resistencia, seguridad y a la precisión del producto.

TRAMONTINA

More than just numbers, what truly defines Tramontina is the constant effort to make people's lives better. The small iron mill founded by Valentin and Elisa Tramontina in 1911 in southern Brazil was the beginning of a group that now encompasses 9 manufacturing units and has kept the century-old tradition of delighting people with simple gestures.

The secret for maintaining this essence is believing in people. Tramontina values each one of its over 10,000 employees so they can deliver functional, stylish products to the market, bringing inspiration to people's daily living and creating experiences to generate value and satisfy clients, consumers and communities.

All this is apparent in the more than 22,000 items that carry the values of a unique brand. Kitchen utensils and equipment, appliances, tools for agriculture, gardening, industrial and automotive maintenance, construction, electrical hardware, wood and plastic furniture, and a wide range of ride-on equipment is manufactured for the domestic market and exported to over 120 countries.

It is by doing beautiful things well that Tramontina and people are brought together. A global player, the company finds the necessary support to deliver solutions that can meet contemporary demands, combining productivity and going over and beyond targets for sustainable development through the environmental management program.

Pleased to meet you, Tramontina!

TRAMONTINA GARIBALDI

Tramontina Garibaldi was founded in 1963 and is located in Garibaldi, RS, Brazil. It now has an industrial area of 98,000 m² and 850 employees manufacturing a wide mix of products for the hand tools market, being present in three different segments.

The PRO Line caters mainly to the industrial and automotive professionals. The Master Line serves the civil construction field. And the Do It Yourself Line serves the domestic use market.

All products comply with strict quality control and manufacturing standards, especially regarding resistance, safety, and accuracy. So the end user can do beautifully well when carrying out assembling, organizing, and repairing tasks.



DIVISIÓN DE HERRAMIENTAS MANUALES | HAND TOOLS DIVISION



DIVISIÓN DE MANGOS Y INSUMOS DE MADERA | HARDWOOD HANDLES AND WOODEN INPUTS DIVISION



DIVISIÓN CENTRO LOGÍSTICO ROTA DO SOL | ROTA DO SOL LOGISTIC CENTER DIVISION



DIVISIÓN ALMACÉN CERRADO TRÊS LAGOAS | DIVISION CLOSED WAREHOUSE TRÊS LAGOAS



DIVISIÓN ORGANIZADORES METÁLICOS | METAL ORGANIZERS DIVISION

TRAMONTINA

PRO

Herramientas industriales, diseñadas para trabajos de alto desempeño.

Industrial tools for high-performance jobs.



INDUSTRIAL | INDUSTRIAL



AGRÍCOLA | AGRICULTURAL



AUTOMOTRIZ | AUTOMOTIVE



HIDROCARBUROS | OIL DRILLING

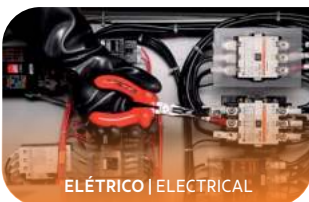

ELÉTRICO | ELECTRICAL



AERONÁUTICA | AERONAUTICAL

TRAMONTINA

MASTER

Herramientas profesionales para la construcción civil.

Professional tools for civil construction.



ALBAÑIL | CONTRACTOR



ELECTRICISTA | ELECTRICIAN



CARPINTERO | CARPENTER



FONTANERO | PLOMBER



CHAPISTA | LOCKSMITH



EBANISTA | JOINER

TRAMONTINA



Herramientas para uso doméstico y para hacer pequeñas reparaciones.

Tools for domestic use and small maintenance tasks.



1	JUEGOS TOOL SETS.....		PAG. 12
----------	--------------------------	---	---------

2	PINZAS PLIERS.....		PAG. 20
----------	-----------------------	---	---------

3	DESTORNILLADORES SCREWDRIVERS.....		PAG. 22
----------	---------------------------------------	---	---------

4	HERRAMIENTAS DE CORTE CUTTING TOOLS.....		PAG. 24
----------	---	---	---------

5	LLAVES DE AJUSTE WRENCHES AND SPANNERS.....		PAG. 26
----------	--	---	---------

6	HERRAMIENTAS DIVERSAS OTHER HAND TOOLS.....		PAG. 30
----------	--	---	---------

7	MALETINES CASES.....		PAG. 32
----------	-------------------------	---	---------

8	GARAJE GARAGE.....		PAG. 42
----------	-----------------------	---	---------

9	EXHIBIDORES DISPLAYS.....		PAG. 67
----------	------------------------------	---	---------

ESTRUCTURA COMERCIAL Y CONDICIONES COMERCIALES BUSINESS STRUCTURE AND COMMERCIAL TERMS.....	PAG. 69
--	---------

43409 Juego de Herramientas | Tool Set

28

PZS | PCS



REF	EAN 789.1114.	Embalaje Package		
		Un	kg	Largo x Ancho x Altura Length x Width x Height (mm)
43409/112	181432	6	4,78	380x305x55

43409 Juego de Herramientas | Tool Set

14

PZS | PCS



REF	EAN 789.1114.	Embalaje Package		
		Un	kg	Largo x Ancho x Altura Length x Width x Height (mm)
43409/113	181425	6	4,65	380x310x40



Cajas para exhibir en el punto de venta Boxes for display at the point of sale

Dos modelos de caja | Two box models

Dimensión de la caja |
Box dimension:

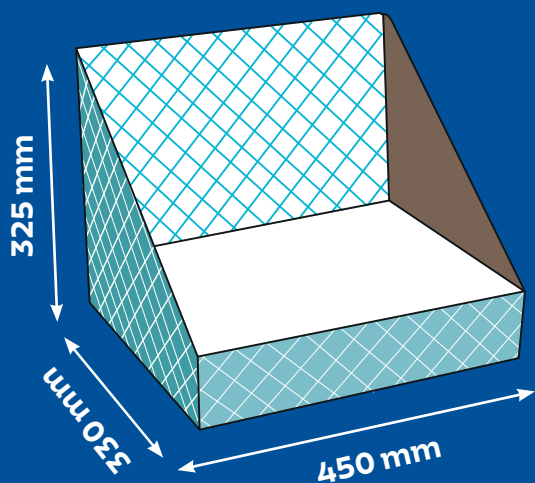

Caja | Box: **1**

Embalaje con: **12 piezas**

Box with: **12 pieces**



Dimensión de la caja |
Box dimension:

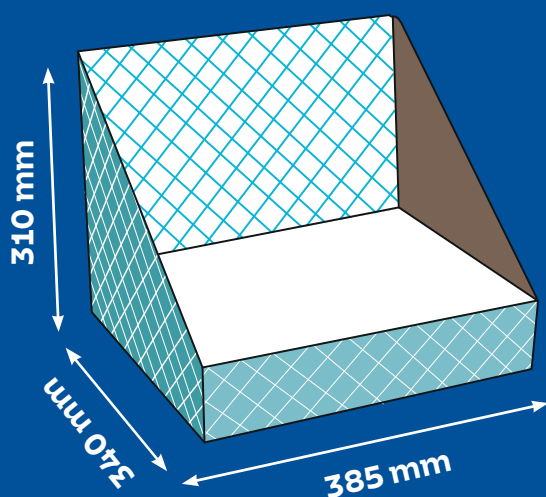

Caja | Box: **2**

Embalaje con: **24 piezas**

Box with: **24 pieces**



Artículos disponibles con caja expositora | References available with display box

Caja | Box: 1 Embalaje con: 12 piezas | Box with: 12 pieces



43409/102

Juego de herramientas | Tool set

Contenido: 1 Linterna 2AA; 1 Cinta métrica 3 m; 2 Destornilladores punta chata 1/8x3" y 3/16x4"; 2 Destornilladores punta cruzada 1/8x3" y 3/16x4"; 1 Cortadora 6".

Set includes: 2AA Plastic flashlight; 3 m Measuring tape; 1/8x3" and 3/16x4"; 2 Slotted tip screwdrivers; 1/8x3" and 3/16x4" Cross recessed tip screwdrivers; 6" Retractable knife.



7
PZS | PCS



43409/107

Juego de herramientas | Tool set

Contenido: 1 Pinza universal aislada 8"; 1 Pinza corte diagonal aislada 6"; 1 Pinza punta media caña aislada 6".

Set includes: 8" Insulated universal pliers; 6" Insulated diagonal cutting pliers; 6" Insulated snipe nose pliers.



3
PZS | PCS



43409/103

Juego de herramientas | Tool set

Contenido: 1 Pinza universal 7"; 1 Cortadora; 3 Llaves fijas 10x11, 12x13 y 14x15 mm; 1 Destornillador punta chata 3/16x3"; 1 Destornillador punta cruzada 3/16x3".

Set includes: 7" Combination pliers; 6" Retractable knife; 10x11, 12x13 and 14x15 mm Open end wrenches; 3/16x3" Slotted tip screwdriver; 3/16x3" Cross recessed tip screwdriver.



7
PZS | PCS



Artículos disponibles con caja expositora | References available with display box

Caja | Box: 2 Embalaje con: 24 piezas | Box with: 24 pieces



41516/507
Juego de destornilladores |
Screwdriver set

Contenido: 3 Destornilladores punta chata: 1/8x3", 3/16x4", 1/4x4"; 2 Destornilladores punta cruzada: 1/8x3" - NR 0 y 3/16x4" - NR 1; 1 Soporte plástico.
Set includes: 3 Slotted pocket tip screwdrivers: 1/8x3", 3/16x4", 1/4x4"; 2 Slotted tip screwdrivers: 1/8x3" - NR 0 and 3/16x4" - NR 1; Plastic handle.



6
PZS | PCS



43408/117
Juego de llaves combinadas |
Combination wrench set

Contenido: 3 Llaves combinadas: 10, 11, 12 mm.
Set includes: 3 Combination wrenches: 10, 11, 12 mm.



3
PZS | PCS



43408/116
Juego de llaves fijas |
Open end wrench set

Contenido: 3 Llaves fijas: 10x11, 12x13 y 14x15 mm.
Set includes: 3 Open end wrenches: 10x11, 12x13 and 14x15 mm.



3
PZS | PCS



43408/122
Juego de herramientas | Tool set

Contenido: 1 Destornillador para punteras; 1 Cinta métrica 2 m; 2 Punteras punta chata 5 y 6,5 mm; 4 Punteras punta cruzada NR 0, NR 1, NR 2 y NR 3.
Set includes: Screwdriver handle bits; 2 m measuring tape; 2 Bits slotted tip: 5 and 6.5 mm; 4 Cross recessed tip bits NR 0, NR 1, NR 2 and NR 3.



8
PZS | PCS



43408/115
Juego de destornilladores |
Screwdriver set

Contenido: 1 Destornillador clip punta chata 1/8x3"; 3 Destornilladores punta chata: 1/8x3", 3/16x4" y 1/4x6"; 3 Destornilladores punta cruzada: 1/8x3", 3/16x3" y 3/16x4".
Set includes: 1/8x3" Slotted pocket tip screwdriver; 3 Slotted tip screwdrivers: 1/8x3", 3/16x3" and 1/4x6"; 3 Cross recessed tip screwdrivers: 1/8x3", 3/16x3" and 3/16x4".



7
PZS | PCS



Caja | Box: 2 Embalaje con: 24 piezas | Box with: 24 pieces



43408/133
Juego de herramientas |
Tool set

Contenido: 1 Llave teste 1/8x3"; 1 Linterna;
1 Cinta métrica 2 m.
Set includes: 1/8x3" Slotted tip voltage
Tester; Flashlight; 2 m Measuring tape.



3
PZS | PCS



43408/142
Juego de herramientas |
Tool set

Contenido: 1 Destornillador clip punta chata
1/8x3"; 1 Cinta métrica 2 m; 1 Linterna 2AA;
1 Destornillador punta chata 1/8x3";
1 Destornillador punta cruzada 1/8x3"-NR 0.
Set includes: 1/8x3" Pocket slotted tip
screwdriver; 2 m Measuring tape;
2AA Plastic flashlight; 1/8x3" Slotted tip
screwdriver; 1/8x3" - NR 0 Cross recessed
tip screwdriver.



5
PZS | PCS



43408/118
Juego de herramientas |
Tool set

Contenido: 1 Cinta métrica 2 m;
1 Cortadora; 1 Destornillador punta chata
3/16x3"; 1 Destornillador punta cruzada
NR 1 - 3/16x3".
Set includes: 2 m Measuring tape;
Retractable knife; 3/16x3" slotted tip
screwdriver; 3/16x3" - NR 1 Cross
recessed tip screwdriver.



4
PZS | PCS



43408/147
Juego de llaves fijas |
Open end wrench set

Contenido: 5 Llaves fijas 6x7, 8x9,
10x11, 12x13, 14x15 mm.
Set includes: 5 Open end wrenches
6x7, 8x9, 10x11, 12x13, 14x15 mm.



5
PZS | PCS



43408/139
Juego de herramientas |
Tool set

Contenido: 1 Llave ajustable 8";
1 Cinta métrica 2 m; 1 Destornillador clip
punta chata 1/8x3"; 2 Destornilladores punta
chata: 1/8x3" y 3/16x3"; 2 Destornilladores
punta cruzada: 1/8" - NR 0 y 3/16x3" - NR 1.
Set includes: 8" Adjustable wrench;
2 m Measuring tape; 1/8x3" Pocket slotted
tip screwdriver; 2 Slotted tip screwdrivers:
1/8x3" and 3/16x3"; 2 Cross recessed tip
screwdrivers: 1/8x3" - NR 0 and 3/16x3" -
NR 1.



7
PZS | PCS



43408/157
Pinza y llave test | Pliers and
voltage tester

Conteúdo: Pinza universal aislada 8";
llave test 1/8x3".
Set includes: 8" Insulated combination
pliers; 1/8x3" Voltage tester.



2
PZS | PCS

Caja | Box: 2 Embalaje con: 24 piezas | Box with: 24 pieces



43408/195
Juego de herramientas | Tool set

Contenido: 1 Martillo de uña 18 mm; Destornillador punta chata 3/16x3" y destornillador punta cruzada 3/16x3" - NR 1.

Set includes: 18 mm Claw hammer; 3/16x3" Slotted tip screwdriver and 3/16x3" - NR 1 Cross recessed tip screwdriver.



3
PZS | PCS



43408/502
Juego de herramientas | Tool set

Contenido: 2 Llaves fijas 10x11 y 14x15 mm; 2 Destornilladores punta chata:

1/8x4" y 3/16x3"; Destornillador punta cruzada 3/16x4" - NR 1.

Set includes: 2 Open and wrenches: 10x11 and 14x15 mm; 2 Slotted tip screwdrivers: 1/8x4" and 3/16x3"; 3/16x4" - NR 1 Cross recessed tip screwdriver.



5
PZS | PCS



43408/304
Juego de herramientas | Tool set

Contenido: 1 Mini arco de sierra; 1 Cortadora; Destornillador punta chata 3/16x3" y destornillador punta cruzada 3/16x3" - NR 1.

Set includes: Mini hacksaw; Retractable knife; 3/16x3" Slotted tip screwdriver and 3/16x3" - NR 1 Cross recessed tip screwdriver.



4
PZS | PCS



43408/505
Juego de herramientas | Tool set

Contenido: 2 Llaves fijas 8x9 y 10x11 mm; 1 Cortadora y 2 Destornilladores punta chata: 1/8x3" y 3/16x3".

Set includes: 2 Open and wrenches: 8x9 and 10x11 mm; Retractable knife and 2 slotted tip screwdrivers: 1/8x3" and 3/16x3".



5
PZS | PCS



43408/500
Juego de herramientas | Tool set

Contenido: 1 Cinta métrica 2 m; 1 Cortadora; 2 Destornilladores punta chata: 1/8x4" y 3/16x4"; 1 Destornillador punta cruzada 3/16x4" - NR 1.

Set includes: 2 m Measuring tape; retractable knife; 2 Slotted tip screwdrivers: 1/8x4" and 3/16x4"; 3/16x4" - NR 1 Cross recessed tip screwdriver.



5
PZS | PCS

Más organización y practicidad!

Much more organization and practicality!

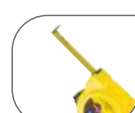

41516 Juego de Destornilladores | Screwdriver Set



6

PZS | PCS

REF	EAN 789.1114.	Embalaje Package		
		Un	kg	Largo x Ancho x Altura Lenght x Width x Height (mm)
41516/507	042528	6	1,65	285x235x90

Contenido | Set includes

5 Destornilladores y 1 soporte plástico.

5 Screwdrivers and 1 plastic hanger;

⊖ 1/8x3"; 3/16x4"; 1/4x4

⊕ 1/8x3" NR 0; 3/16x4" NR 1

Caja | Box 2

42808 Juego de Llaves de Pipa para Moto | Motorcycle Hollow Offset Set



3

PZS | PCS

REF	EAN 789.1114.	Embalaje Package		
		Un	kg	Largo x Ancho x Altura Lenght x Width x Height (mm)
42808/103	110999	12	5,12	285x235x90

Contenido | Set includes

3 Llaves pipa abierta: 8, 10 y 12 mm.

3 Hollow offset pipe wrenches: 8, 10 and 12 mm.

43408 Juego de Herramientas | Tool Set



7

PZS | PCS

REF	EAN 789.1114.	Embalaje Package		
		Un	kg	Largo x Ancho x Altura Lenght x Width x Height (mm)
43408/109	068955	12	2,60	340x265x105

Contenido | Set includes

3 Destornilladores punta chata 1/8x3", 3/16x3", 1/4x4";
2 Destornilladores punta cruzada NR 0 - 1/8x3", NR 1 - 3/16x3";
1 Llave test 1/8x3"; 1 Mini destornillador.

3 Slotted tip screwdrivers: 1/8x3", 3/16x3", 1/4x4"; 2 Cross recessed tip screwdrivers: NR 0 - 1/8x3", NR 1 - 3/16x3"; 1/8x3" voltage tester; Mini screwdriver.

Caja | Box 2

43408 Juego de Herramientas | Tool Set

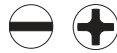

4

PZS | PCS

REF	EAN 789.1114.	Embalaje Package		
		Un	kg	Largo x Ancho x Altura Lenght x Width x Height (mm)
43408/112	068962	12	5,20	340x265x135

Contenido | Set includes

1 Pinza universal 6"; 1 Cinta métrica 2 m; 1 Destornillador punta chata 3/16x3"; 1 Destornillador punta cruzada NR 1 - 3/16x3".

6" Combination pliers; 2 m Measuring tape; 3/16x3" Slotted tip screwdriver; Cross recessed tip screwdriver NR 1 - 3/16x3".

Caja | Box 2

43408 Juego de Herramientas | Tool Set



6
PZS | PCS

REF	EAN 789.1114.	Embalaje Package		
		Un	kg	Largo x Ancho x Altura Length x Width x Height (mm)
43408/113	068979	12	5,96	345x315x140

Contenido | Set includes

1 Martillo de uña 18 mm; 2 llaves fijas 8x9 y 10x11 mm;
1 Cortadora retráctil; 1 destornillador punta chata 3/16x3";
1 Destornillador punta cruzada NR 1 - 3/16x3".

18 mm Claw hammer; 2 Open end wrenches 8x9 and 10x11 mm;
Retractable knife; Slotted tip screwdriver 3/16x3";
Cross recessed tip screwdriver NR 1 - 3/16x3".

Caja | Box **2**

43408 Juego de Destornilladores | Screwdriver Set



7
PZS | PCS

REF	EAN 789.1114.	Embalaje Package		
		Un	kg	Largo x Ancho x Altura Length x Width x Height (mm)
43408/115	067279	12	2,85	325x245x110

Contenido | Set includes

3 Destornilladores punta chata: 1/8x3", 3/16x4" y 1/4x6";
3 Destornilladores punta cruzada: 1/8x3", 3/16x3" y 3/16x4";
1 Destornillador clip punta chata 1/8x3"

3 Slotted tip screwdrivers: 1/8x3", 3/16x4 and 1/4x6"
3 Cross recessed tip screwdrivers: 1/8x3", 3/16x3" and 3/16x4";
Slotted tip pocket screwdriver 1/8x3".

Caja | Box **2**

43408 Juego de Llaves Fijas | Open End Wrench Set



3
PZS | PCS

REF	EAN 789.1114.	Embalaje Package		
		Un	kg	Largo x Ancho x Altura Length x Width x Height (mm)
43408/116	067255	12	1,92	230x200x100

Contenido | Set includes

3 Llaves fijas: 10x11, 12x13 y 14x15 mm.

3 Open end wrenches: 10x11, 12x13 and 14x15 mm.

Caja | Box **2**

43408 Juego de Llaves Combinadas | Combination Wrench Set



3
PZS | PCS

REF	EAN 789.1114.	Embalaje Package		
		Un	kg	Largo x Ancho x Altura Length x Width x Height (mm)
43408/117	067262	12	2,46	230x200x100

Contenido | Set includes

3 Llaves combinadas: 10,11 y 12 mm.

3 Combination wrenches: 10, 11 and 12 mm.

Caja | Box **2**



43408 Juego de Herramientas | Tool Set

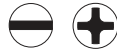

4
PZS | PCS

REF	EAN 789.1114.	Embalaje Package		
		Un	kg	Largo x Ancho x Altura Length x Width x Height (mm)
43408/118	067286	12	2,60	345x315x140

Contenido | Set includes

1 Cinta métrica 2 m; 1 Cortadora; 1 Destornillador punta chata 3/16x3"; 1 Destornillador punta cruzada NR 1 - 3/16x3".

2 m Measuring tape; Retractable knife; 3/16x3" Slotted tip screwdriver; 3/16x3" - NR 1 Cross recessed tip screwdriver.

Caja | Box **2**

43408 Juego de Pinzas | Pliers Set



3
PZS | PCS

REF	EAN 789.1114.	Embalaje Package		
		Un	kg	Largo x Ancho x Altura Length x Width x Height (mm)
43408/120	068993	12	2,63	340x265x105

Contenido | Set includes

1 Pinza media caña 5"; 1 Pinza corte diagonal 4"; 1 Pinza punta redonda 5".

5" Snipe nose pliers; 4" Diagonal cutting pliers; 5" Round nose pliers.

Caja | Box **2**

43408 Juego de Herramientas | Tool Set

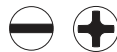

8
PZS | PCS

REF	EAN 789.1114.	Embalaje Package		
		Un	kg	Largo x Ancho x Altura Length x Width x Height (mm)
43408/122	067293	12	3,18	380x220x130

Contenido | Set includes

1 Destornillador para punteras; 1 Cinta métrica 2 m; 2 Punteras punta chata: 5 y 6,5 mm; 4 Punteras punta cruzada: NR 0, NR 1, NR 2 y NR 3.

Bits handle screwdriver; 2 m Measuring tape; 2 Slotted tip bits: 5 and 6,5 mm; 4 Cross recessed tip bits: NR 0, NR 1, NR 2 and NR 3.

Caja | Box **2**

43408 Juego de Herramientas | Tool Set



10
PZS | PCS

REF	EAN 789.1114.	Embalaje Package		
		Un	kg	Largo x Ancho x Altura Length x Width x Height (mm)
43408/123	077636	12	3,42	345x315x140

Contenido | Set includes

1 Destornillador para punteras; 1 linterna; 1 Cinta métrica 2 m; 1 Cortadora; 2 Punteras punta chata: 5 y 6,5 mm; 4 Punteras punta cruzada: NR 0, NR 1, NR 2 y NR 3.

Bits handle screwdriver; Flashlight; 2 m Measuring tape; Retractable knife; 2 Slotted tip bits: 5 and 6,5 mm; 4 Cross recessed tip bits: NR 0, NR 1, NR 2 and NR 3.

Caja | Box **2**

43408 Juego de Herramientas | Tool Set



3
PZS | PCS

REF	EAN	Embalaje Package		
		Un	kg	Largo x Ancho x Altura Length x Width x Height (mm)
43408/133	077650	12	1,78	340x265x135

Contenido | Set includes

1 Llave teste 1/8x3"; 1 Linterna; 1 Cinta métrica 2 m.
1/8x3" Slotted tip voltage tester; Flashlight; 2 m Measuring tape.

Caja | Box **2**

43408 Juego de Herramientas | Tool Set

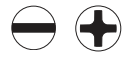

4
PZS | PCS

REF	EAN	Embalaje Package		
		Un	kg	Largo x Ancho x Altura Length x Width x Height (mm)
43408/134	072709	12	3,00	345x315x140

Contenido | Set includes

1 Nivel plástico 230 mm; 1 Cinta métrica 2 m; 1 Destornillador punta chata 1/8x3"; 1 Destornillador punta cruzada 1/8x3" - NR 0.
230 mm Plastic level; 2 m Measuring tape; 1/8x3" Slotted tip screwdriver; 1/8x3" - NR 0 Cross recessed tip screwdriver.

Caja | Box **2**

43408 Juego de Herramientas | Tool Set

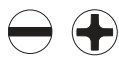

5
PZS | PCS

REF	EAN	Embalaje Package		
		Un	kg	Largo x Ancho x Altura Length x Width x Height (mm)
43408/137	072730	12	7,73	345x315x140

Contenido | Set includes

1 Martillo de uña 18 mm; 1 Mini arco de sierra 10"; 1 Cinta métrica 2 m; 1 Destornillador punta chata 3/16x3"; 1 Destornillador punta cruzada 3/16x3" - NR 1.
18 mm Claw hammer; 10" Mini hacksaw; 2 m Measuring tape; 3/16x3" Slotted tip screwdriver; 3/16x3" - NR 1 Cross recessed tip screwdriver.

Caja | Box **2**

43408 Juego de Herramientas | Tool Set



4
PZS | PCS

REF	EAN	Embalaje Package		
		Un	kg	Largo x Ancho x Altura Length x Width x Height (mm)
43408/138	072747	12	3,53	340x265x135

Contenido | Set includes

1 Pinza universal 6"; 1 Llave test punta chata 1/8x3"; 1 Cortadora; 1 Cinta métrica 2 m.
6" Combination pliers; 1/8x3" Slotted tip voltage tester; Retractable knife; 2 m Measuring tape.

Caja | Box **2**



43408 Juego de Herramientas | Tool Set

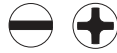

7

PZS | PCS

REF	EAN 789.1114.	Embalaje Package		
		Un	kg	Largo x Ancho x Altura Length x Width x Height (mm)
43408/139	072754	12	6,43	340x265x135

Contenido | Set includes

1 Llave ajustable 8"; 1 Cinta métrica 2 m; 1 Destornillador clip punta chata 1/8x3"; 2 Destornilladores punta chata: 1/8x3" y 3/16x3"; 2 Destornilladores punta cruzada: 1/8" - NR 0 y 3/16x3" - NR 1.

8" Adjustable wrench, 2 m Measuring tape; 1/8x3" Pocket slotted tip screwdriver; 2 Slotted tip screwdrivers: 1/8x3" and 3/16x3"; 2 Cross recessed tip screwdrivers: 1/8x3"- NR 0 and 3/16x3" - NR 1.

Caja | Box **2**

43408 Juego de Herramientas | Tool Set



6

PZS | PCS

REF	EAN 789.1114.	Embalaje Package		
		Un	kg	Largo x Ancho x Altura Length x Width x Height (mm)
43408/141	072778	12	5,29	345x315x140

Contenido | Set includes

1 Pinza universal 6"; 1 Cortadora; 1 Cinta métrica 2 m; 1 Destornillador clip punta chata 1/8x3"; 1 Destornillador punta chata 3/16x3"; 1 Destornillador punta cruzada 3/16x3" - NR 1.

6" Combination pliers; Retractable knife; 2 m Measuring tape; 1/8x3" Pocket slotted tip screwdriver; 3/16x3" Slotted tip screwdriver; 3/16x3" - NR 1 Cross recessed tip screwdriver.

Caja | Box **2**

43408 Juego de Herramientas | Tool Set



5

PZS | PCS

REF	EAN 789.1114.	Embalaje Package		
		Un	kg	Largo x Ancho x Altura Length x Width x Height (mm)
43408/142	077667	12	2,82	340x265x135

Contenido | Set includes

1 Destornillador clip punta chata 1/8x3"; 1 Cinta métrica 2 m; 1 linterna 2AA; 1 Destornillador punta chata 1/8x3"; 1 Destornillador punta cruzada 1/8x3" - NR 0.

1/8x3" Pocket slotted tip screwdriver; 2 m Measuring tape; 2AA Flashlight; 1/8x3" Slotted tip screwdriver; 1/8x3" - NR 0 Cross recessed tip screwdriver.

Caja | Box **2**

43408 Juego de Llaves Fijas | Open End Wrench Set



5

PZS | PCS

REF	EAN 789.1114.	Embalaje Package		
		Un	kg	Largo x Ancho x Altura Length x Width x Height (mm)
43408/147	077711	12	2,70	340x265x105

Contenido | Set includes

5 Llaves fijas 6x7, 8x9, 10x11, 12x13, 14x15 mm.

5 Open end wrenches 6x7, 8x9, 10x11, 12x13, 14x15 mm.

Caja | Box **2**

43408 Juego de Llaves Combinadas |
Combination Wrench Set



6
PZS | PCS

REF	EAN 789.1114.	Embalaje Package		
		Un	kg	Largo x Ancho x Altura Lenght x Width x Height (mm)
43408/148	077728	12	3,29	340x265x105

Contenido | Set includes

4 Llaves combinadas: 8, 10, 11, 13 mm.

4 Combination wrenches: 8, 10, 11, 13 mm.

Caja | Box **2**

43408 Juego de Llaves Fijas y Combinadas |
Open End and Combination Wrench Set



4
PZS | PCS

REF	EAN 789.1114.	Embalaje Package		
		Un	kg	Largo x Ancho x Altura Lenght x Width x Height (mm)
43408/152	077766	12	5,45	340x265x105

Contenido | Set includes

3 Llaves fijas: 6x7, 8x9, 10x11 mm; 3 llaves combinadas: 12, 13, 14 mm.

3 Open end wrenches: 6x7, 8x9, 10x11 mm; 3 Combination wrenches: 12, 13, 14 mm.

Caja | Box **2**

43408 Juego de Herramientas | Tool Set



36
PZS | PCS

REF	EAN 789.1114.	Embalaje Package		
		Un	kg	Largo x Ancho x Altura Lenght x Width x Height (mm)
43408/187	103458	12	4,80	280x218x156

Contenido | Set includes

Punteras | Bits screwdriver handle:

10 dados | Sockets: 4; 5; 6; 7; 8; 9; 10; 11; 12; 13 mm.

25 punteras | tips:

3; 4; 5; 6.5 mm.

NR 0; NR 1; NR 2; NR 3; NR 4.

2; 3; 4; 5; 6 mm.

T10; T15; T20; T25; T30; T40.

PZ0; PZ1; PZ2; PZ3; PZ4.

Caja | Box **2**

43408 Juego de Herramientas | Tool Set



4
PZS | PCS

REF	EAN 789.1114.	Embalaje Package		
		Un	kg	Largo x Ancho x Altura Lenght x Width x Height (mm)
43408/189	449778	12	1,01	340x265x135

Contenido | Set includes

1 Destornillador punta chata 1/8x3"; 1 Cinta aisladora; 1 Cinta para sellado de roscas y conector.

1/8x3" Slotted tip screwdriver; Insulating tape; Thread seal tape and 3 posts multiple connector.

Caja | Box **2**

43408 Juego de Herramientas | Tool Set



3

PZS | PCS

REF	EAN 789.1114.	Embalaje Package		
		Un	kg	Largo x Ancho x Altura Length x Width x Height (mm)
43408/195	449839	12	4,47	345x315x140

Contenido | Set includes

1 Martillo de uña 18 mm; 1 Destornillador punta chata 3/16x3";
1 Destornillador punta cruzada 3/16x3" - NR 1.

18 mm Claw hammer, 3/16x3" Slotted tip screwdriver;
3/16x3" - NR 1 Cross recessed tip screwdriver.

Caja | Box **2**

43408 Juego de Herramientas | Tool Set

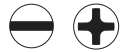

4

PZS | PCS

REF	EAN 789.1114.	Embalaje Package		
		Un	kg	Largo x Ancho x Altura Length x Width x Height (mm)
43408/304	016260	12	2,71	345x315x140

Contenido | Set includes

1 Mini arco de sierra; 1 Cortadora; 1 Destornillador punta chata
3/16x3"; 1 Destornillador punta cruzada 3/16x3" - NR 1.

Mini hacksaw; Retractable knife; 3/16x3" Slotted tip screwdriver;
3/16x3" - NR1 Cross recessed tip screwdriver.

Caja | Box **2**

43408 Juego de Herramientas | Tool Set

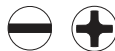

5

PZS | PCS

REF	EAN 789.1114.	Embalaje Package		
		Un	kg	Largo x Ancho x Altura Length x Width x Height (mm)
43408/500	048391	12	3,00	440x250x117

Contenido | Set includes

1 Cinta métrica 2 m; 1 Cortadora; 2 Destornilladores punta chata:
1/8x4" y 3/16x4"; 1 Destornillador punta cruzada
3/16x4" - NR 1.

2 m Measuring tape; Retractable knife; 2 Slotted tip screwdrivers:
1/8x4" and 3/16x4"; 3/16x4" - NR1 Cross recessed tip screwdriver.

Caja | Box **2**

43408 Juego de Herramientas | Tool Set



5

PZS | PCS

REF	EAN 789.1114.	Embalaje Package		
		Un	kg	Largo x Ancho x Altura Length x Width x Height (mm)
43408/502	048568	12	3,74	340x265x105

Contenido | Set includes

2 Llaves fijas: 10x11 y 14x15 mm; 2 Destornilladores punta chata:
1/8x4" y 3/16x3"; 1 Destornillador punta cruzada 3/16x4" - NR 1.

2 Open and wrenches: 10x11 and 14x15 mm; 2 Slotted tip screwdrivers:
1/8x4" and 3/16x3"; 3/16x4" - NR1 Cross recessed tip screwdriver.

Caja | Box **2**

43408 Juego de Herramientas | Tool Set



5
PZS | PCS

REF	EAN 789.1114.	Embalaje Package		
		Un	kg	Largo x Ancho x Altura Length x Width x Height (mm)
43408/505	038309	12	2,54	340x265x105

Contenido | Set includes

2 Llaves fijas: 8x9 y 10x11 mm; 1 Cortadora; 2 Destornilladores punta chata: 1/8x3" y 3/16x3".

2 Open and wrenches: 8x9 and 10x11 mm, Retractable knife;
2 Slotted tip screwdrivers: 1/8x3" and 3/16x3".

Caja | Box **2**



41002 Pinza Universal | Combination Pliers - 7"



REF	EAN 789.1114.	Embalaje Package		
		Un	kg	Largo x Ancho x Altura Length x Width x Height (mm)
41002/107	061321	12	2,67	245x215x80

Características | Characteristics

Cuerpo forjado en acero especial. Acabado fosfatado. Cabeza y articulación pulidas. Temple especial en el hilo de corte. Mangos con revestimiento especial.

Forged body in special steel. Phosphated finishing. Polished head and joint. Special hardening at the cutting edge. Handles with special coating.

41105 Pinza Punta Media Caña | Snipe Nose Pliers - 5"



REF	EAN 789.1114.	Embalaje Package		
		Un	kg	Largo x Ancho x Altura Length x Width x Height (mm)
41105/301	063981	12	1,02	210x90x115

Características | Characteristics

Cuerpo forjado en acero especial y templado. Cabeza y articulación pulidas. Temple especial en el hilo de corte. Mangos con revestimiento especial.

Forged and hardened body in special steel. Polished head and joint. Special hardening at the cutting edge. Handles with special coating.

41105 Pinza Corte Diagonal | Diagonal Cutting Pliers - 4"



REF	EAN 789.1114.	Embalaje Package		
		Un	kg	Largo x Ancho x Altura Length x Width x Height (mm)
41105/302	063998	12	0,88	210x85x115

Características | Characteristics

Cuerpo forjado en acero especial y templado. Cabeza y articulación pulidas. Temple especial en el hilo de corte. Mangos con revestimiento especial.

Forged and hardened body in special steel. Polished head and joint. Special hardening at the cutting edge. Handles with special coating.

41105 Pinza Punta Redonda | Round Nose Pliers - 5"



REF	EAN 789.1114.	Embalaje Package		
		Un	kg	Largo x Ancho x Altura Length x Width x Height (mm)
41105/303	064001	12	0,96	210x85x115

Características | Characteristics

Cuerpo forjado en acero especial y templado. Cabeza y articulación pulidas. Temple especial en el hilo de corte. Mangos con revestimiento especial.

Forged and hardened body in special steel. Polished head and joint. Special hardening at the cutting edge. Handles with special coating.

41135 Cincel con Cuerpo Redondo | Stone Chisel with Round Body



REF	Tamaño Size
41135/110	10"
41135/112	12"
41135/114	14"

REF	EAN 789.1114.	Embalaje Package		
		Un	kg	Largo x Ancho x Altura Length x Width x Height (mm)
41135/110	069259	6	2,99	330x160x60
41135/112	069266	6	3,63	380x160x60
41135/114	069273	6	4,13	430x160x60

Características | Characteristics

Cuerpo en acero especial. Acabado por pintura electrostática negra. Temple por inducción en las dos extremidades. Diámetro de 18 mm.

Special steel body. Electrostatic painting in black color. Induction hardening at the both edges. 18 mm diameter.

41136 Cincel de Punta con Cuerpo Redondo | Stone Pointed Chisel with Round Body



REF	Tamaño Size
41136/110	10"
41136/112	12"
41136/114	14"

REF	EAN 789.1114.	Embalaje Package		
		Un	kg	Largo x Ancho x Altura Length x Width x Height (mm)
41136/110	069280	6	2,89	330x160x60
41136/112	069297	6	3,45	380x160x60
41136/114	069303	6	4,06	430x160x60

Características | Characteristics

Cuerpo en acero especial. Acabado por pintura electrostática negra. Temple por inducción en las dos extremidades. Diámetro de 18 mm.

Special steel body. Electrostatic painting in black color. Induction hardening at the both edges. 18 mm diameter.

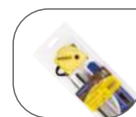
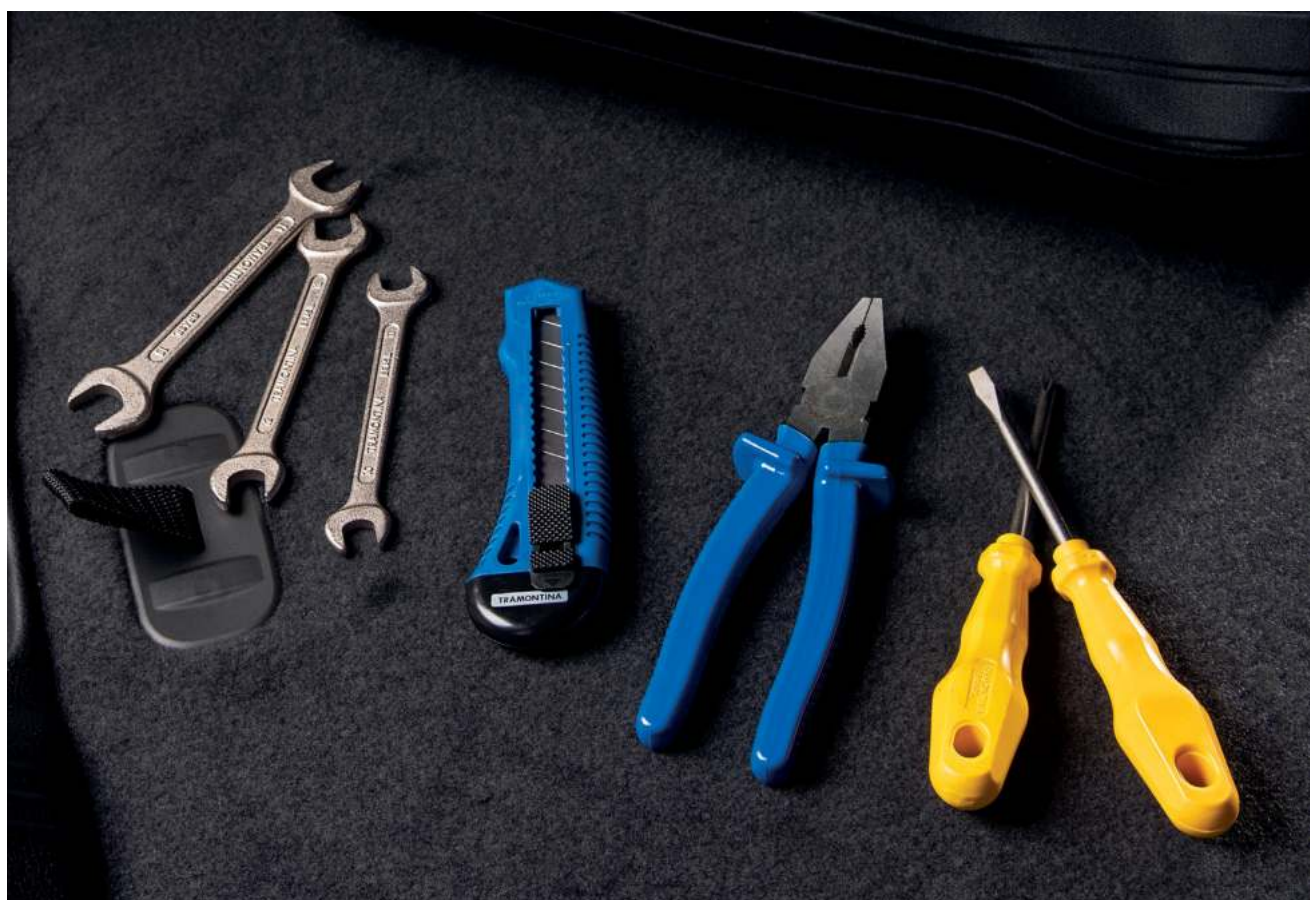

41110 Juego de Destornilladores | Screwdriver Set



6
PZS | PCS

REF	EAN 789.1114.	Embalaje Package		
		Un	kg	Largo x Ancho x Altura Length x Width x Height (mm)
41110/506	088175	12	2,87	280x218x156

Contenido | Set includes

1 Mango para astas intercambiables; 3 Astas intercambiables punta chata 1/8x3", 3/16x3" y 1/4x3"; 3 Astas intercambiables punta cruzada 1/8x3", 3/16x3" y 1/4x3".

Handle for interchangeable blades; 3 Slotted tip interchangeable blades 1/8x3", 3/16x3" and 1/4x3"; 3 Cross recessed tip interchangeable blades 1/8x3", 3/16x3" and 1/4x3".

41990 Mini Destornillador | Mini Screwdriver



REF	Tamaño Size
41990/000	5x30 mm (3/16x1")

REF	EAN 789.1114.	Embalaje Package		
		Un	kg	Largo x Ancho x Altura Length x Width x Height (mm)
41990/000	011265	100	1,08	265x110x70

41516 Juego de Destornilladores | Screwdriver Set



6
PZS | PCS

REF	EAN 789.1114.	Embalaje Package		
		Un	kg	Largo x Ancho x Altura Length x Width x Height (mm)
41516/536	140514	6	2,70	515x345x105

Contenido | Set includes

4 Destornilladores punta chata: 5x75 (3/16x3"), 5x150 (3/16x6"), 6x100 (1/4x4"), 6x150 mm (1/4x6"). 2 Destornilladores punta cruzada: 5x100 (NR 1 - 3/16x4"), 6x100 mm (NR 2 - 1/4x4").

4 Slotted tip screwdrivers: 5x75 (3/16x3"), 5x150 (3/16x6"), 6x100 (1/4x4"), 6x150 mm (1/4x6"). 2 Cross recessed tip screwdrivers: 5x100 (NR 1 - 3/16x4"), 6x100 mm (NR 2 - 1/4x4").

43408 Juego de Destornilladores | Screwdriver Set

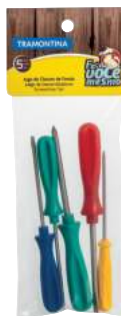

5
PZS | PCS

REF	EAN 789.1114.	Embalaje Package		
		Un	kg	Largo x Ancho x Altura Length x Width x Height (mm)
43408/176	092745	12	1,53	265x220x115

Contenido | Set includes

2 Destornilladores punta chata: 1/8x3" y 3/16x3"; 2 Destornilladores punta cruzada: 1/8x3" (NR 0) y 3/16x3" (NR 1); 1 Destornillador clip punta chata 1/8x3".

2 Slotted tip screwdrivers: 1/8x3" and 3/16x3"; 2 Cross recessed tip screwdrivers: 1/8x3" (NR 0) and 3/16x3" (NR 1); 1/8x3" Pocket slotted tip screwdriver.

43411 Destornillador con Punteras | Screwdriver with Tips



6
PZS | PCS

REF	EAN 789.1114.	Embalaje Package		
		Un	kg	Largo x Ancho x Altura Length x Width x Height (mm)
43411/001	051964	12	2,05	270x235x90

Contenido | Set includes

6 punteras | 6 bits
5; 6.5 mm;



0; 1; 2; 3.



43200 Serrucho Utility | Utility Saw



REF	Tamaño Size	EAN 789.1114.	Embalaje Package		
			Un	kg	Largo x Ancho x Altura Length x Width x Height (mm)
43200/016	16"	004861	6	2,52	545x140x90
43200/018	18"	001174	6	2,81	545x140x90
43200/020	20"	001181	6	2,94	605x155x85
43200/022	22"	001198	6	2,94	645x175x95

Características | Characteristics

7 Dientes por pulgada | 7 Teeth per inch

Lámina en acero especial templada y lijada. Mango de madera barnizado.
Dientes trabados. Protección plástica en el área de corte.

Hardened and polished special steel blade. Varnished hardwood handle.
Set teeth. Plastic protection for the cutting area.

43204 Serrucho Utility | Utility Saw



REF	Tamaño Size	EAN 789.1114.	Embalaje Package		
			Un	kg	Largo x Ancho x Altura Length x Width x Height (mm)
43204/916	16"	058048	6	2,00	545x140x90

Características | Characteristics

7 Dientes por pulgada | 7 Teeth per inch

Lámina en acero especial templada y lijada. Mango inyectado.
Dientes trabados. Protección plástica en el área de corte.

Hardened and polished special steel blade. Injected handle.
Set teeth. Plastic protection for the cutting area.

43291 Serrucho de Poda Utility | Utility Pruning Saw



REF	Tamaño Size	EAN 789.1114.	Embalaje Package		
			Un	kg	Largo x Ancho x Altura Length x Width x Height (mm)
43291/012	12"	009620	6	0,97	555x90x75

Características | Characteristics

5 Dientes por pulgada | 5 Teeth per inch

Lámina en acero especial templada y lijada. Mango inyectado.
Dientes trabados. Protección plástica en el área de corte.

Hardened and polished special steel blade. Injected handle.
Set teeth. Plastic protection for the cutting area.

43290 Serrucho de Poda | Pruning Saw



REF	Tamaño Size	EAN 789.1114.	Embalaje Package		
			Un	kg	Largo x Ancho x Altura Length x Width x Height (mm)
43290/012	12"	004823	6	1,27	455x84x110

Características | Characteristics

5 Dientes por pulgada | 5 Teeth per inch

Lámina en acero alto carbono templada. Mango de madera. Dientes trabados.
Protección plástica en el área de corte.

Hardened high carbon steel blade. Wood handle. Set teeth. Plastic protection for
the cutting area.

43315 Mini Arco de Sierra | Mini Hacksaw



REF	Tamaño Size	EAN 789.1114.	Embalaje Package		
			Un	kg	Largo x Ancho x Altura Length x Width x Height (mm)
43315/012	10"	026825	12	0,60	355x110x70

Características | Characteristics

Mango ergonómico inyectado.

Ergonomic injected handle.

43303 Mini Arco de Sierra | Mini Hacksaw



REF	Tamaño Size	EAN 789.1114.	Embalaje Package		
			Un	kg	Largo x Ancho x Altura Length x Width x Height (mm)
43303/006	6"	117943	12	1,66	265x105x160

Características | Characteristics

Cuerpo en acero. Empuñadura inyectada en plástico y recubierta con goma. Para plásticos y maderas.

Steel body. Rubber covered injected plastic handle. For plastic and wood.

43390 Cortadora | Retractable Knife



REF	Tamaño Size	EAN 789.1114.	Embalaje Package		
			Un	kg	Largo x Ancho x Altura Length x Width x Height (mm)
43390/300	6"	009668	12	0,77	220x160x130

Características | Characteristics

Cuerpo inyectado. Láminas en acero especial templado. Dispositivo con traba de seguridad.

Injected body. Hardened special steel blade. Safety lock system for the blade.

41170 Cortadora | Retractable Knife



REF	Tamaño Size (mm)	EAN 789.1114.	Embalaje Package		
			Un	kg	Largo x Ancho x Altura Length x Width x Height (mm)
41170/300	130	061505	12	0,35	220x110x100

Características | Characteristics

Cuerpo inyectado. Láminas en acero especial templado. Dispositivo con traba de seguridad.

Injected body. Hardened special steel blade. Safety lock system for the blade.



43301 Arco de Sierra Fijo | Hacksaw



REF	Tamaño Size	EAN 789.1114.	Embalaje Package		
			Un	kg	Largo x Ancho x Altura Length x Width x Height (mm)
43301/012	12"	001266	12	5,39	485x200x135

Características | Characteristics

Pintura electrostática. Lámina de 12". Mango ergonómico inyectado. Utilizado para corte de acero, metales no ferrosos, como aluminio y cobre, plástico, madera, acrílico, entre otros.

Electrostatic painting. 12" blade. Ergonomic injected handle. Used to cut steel and nonferrous material such as aluminum, cooper, plastic, wood, acrylic, etc.

41120 Llave Fija | Open End Wrench



REF	Tamaño Size (mm)	EAN 789.1114.	Embalaje Package		
			Un	kg	Largo x Ancho x Altura Length x Width x Height (mm)
41120/101	6x7	063448	12	0,39	195x110x70
41120/102	8x9	063455	12	0,46	195x110x70
41120/103	10x11	063462	12	0,54	265x110x70
41120/104	12x13	063479	12	0,74	265x110x70
41120/105	14x15	063486	12	0,95	265x110x70
41120/106	16x17	063493	6	0,61	265x110x70
41120/107	18x19	092882	6	0,77	265x110x70
41120/108	20x22	092899	6	1,09	265x110x70
41120/109	21x23	092905	6	1,16	265x110x70
41120/110	24x26	092912	6	1,63	265x110x70
41120/111	25x28	092929	6	1,81	335x110x70
41120/112	27x32	092936	6	2,52	335x110x70
41120/113	30x32	094046	6	2,67	335x110x70

Características | Characteristics

Cuerpo forjado en acero especial y templado. Acabado cromado. Apertura de las bocas calibradas.

Forged and hardened body in special steel. Chrome plated finishing. Calibrated openings.

43303 Juego de Láminas para Mini Arco | Mini Hacksaw Blade Set

5
PZS | PCS



REF	EAN 789.1114.	Embalaje Package		
		Un	kg	Largo x Ancho x Altura Length x Width x Height (mm)
43303/905	125177	12	0,46	335x110x70

Características | Characteristics

5 Láminas para mini arco 43303/006.

5 Mini hack-saw blade set 43303/006.

41120 Juego de Llaves Fijas | Open End Wrench Set

5
PZS | PCS



REF	EAN 789.1114.	Embalaje Package		
		Un	kg	Largo x Ancho x Altura Length x Width x Height (mm)
41120/205	071863	6	2,15	260x235x110

Contenido | Set includes

5 Llaves fijas: 8x9, 10x11, 12x13, 14x15 y 16x17 mm; Embalaje plástica.

5 Open end wrenches: 8x9, 10x11, 12x13, 14x15 and 16x17 mm; Plastic roll pouch.

41120 Juego de Llaves Fijas |
Open End Wrench Set



8
PZS | PCS

REF	EAN 789.1114.	Embalaje Package		
		Un	kg	Largo x Ancho x Altura Length x Width x Height (mm)
41120/208	094251	6	3,84	280x195x100

Contenido | Set includes

8 Llaves fijas: 6x7, 8x9, 10x11, 12x13, 14x15, 16x17, 18x19 y 20x22 mm; Embalaje plástica.

8 Open end wrenches: 6x7, 8x9, 10x11, 12x13, 14x15, 16x17, 18x19 and 20x22 mm; Plastic roll pouch.

41120 Juego de Llaves Fijas |
Open End Wrench Set

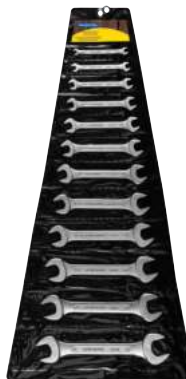

12
PZS | PCS

REF	EAN 789.1114.	Embalaje Package		
		Un	kg	Largo x Ancho x Altura Length x Width x Height (mm)
41120/212	094268	6	11,19	380x230x210

Contenido | Set includes

12 Llaves fijas: 6x7, 8x9, 10x11, 12x13, 14x15, 16x17, 18x19, 20x22, 21x23, 24x26, 25x28 y 27x32 mm; Embalaje plástica.

12 Open end wrenches: 6x7, 8x9, 10x11, 12x13, 14x15, 16x17, 18x19, 20x22, 21x23, 24x26, 25x28 and 27x32 mm; plastic roll pouch.

41016 Llave Ajustable | Adjustable Wrench



REF	Tamaño Size	EAN 789.1114.	Embalaje Package		
			Un	kg	Largo x Ancho x Altura Length x Width x Height (mm)
41016/506	6"	068290	6	0,91	230x95x100
41016/508	8"	068306	6	1,66	275x120x80
41016/510	10"	062717	6	2,80	320x100x100
41016/512	12"	062724	6	4,12	400x140x90

41409 Juego de Llaves Hexagonales |
Hex Key Set



9
PZS | PCS

REF	EAN 789.1114.	Embalaje Package		
		Un	kg	Largo x Ancho x Altura Length x Width x Height (mm)
41409/209	118537	6	1,83	230x160x95

Contenido | Set includes

9 Llaves hexagonales: 1.5, 2, 2.5, 3, 4, 5, 6, 8 y 10 mm.

9 Hex keys: 1.5, 2, 2.5, 3, 4, 5, 6, 8 and 10 mm.



41128 Llave Combinada | Combination Wrench



REF	Tamaño Size (mm)	EAN 789.1114.	Embalaje Package		
			Un	kg	Largo x Ancho x Altura Length x Width x Height (mm)
41128/106	6	063509	12	0,32	195x110x70
41128/107	7	063516	12	0,38	195x110x70
41128/108	8	063523	12	0,43	195x110x70
41128/109	9	063530	12	0,52	195x110x70
41128/110	10	063547	12	0,64	265x110x70
41128/111	11	063554	12	0,78	265x110x70
41128/112	12	063561	12	0,85	265x110x70
41128/113	13	063578	12	0,99	265x110x70
41128/114	14	063585	12	1,11	265x110x70
41128/115	15	063592	12	1,23	265x110x70
41128/116	16	063608	6	0,75	265x110x70
41128/117	17	063615	6	0,84	265x110x70
41128/118	18	066609	6	0,99	265x110x70
41128/119	19	066616	6	1,11	335x110x70
41128/120	20	093117	6	1,35	335x110x70
41128/121	21	093124	6	1,55	335x110x70
41128/122	22	093131	6	1,65	335x110x70
41128/123	23	093148	6	1,84	335x110x70
41128/124	24	093155	6	2,20	335x110x70
41128/25	25	093162	6	2,20	335x110x70
41128/126	26	093179	6	2,47	335x110x70
41128/127	27	093186	6	2,79	435x110x70
41128/128	28	093193	6	3,15	435x110x70
41128/130	30	093209	6	3,42	495x105x95
41128/132	32	093216	6	3,80	495x105x95

Características | Characteristics

Cuerpo forjado en acero especial y templado. Acabado cromado. Apertura de las bocas calibradas. Cuello corto.

Forged and hardened body in special steel. Chrome plated finishing. Calibrated openings. Short neck.

41128 Juego de Llaves Combinadas | Combination Wrench Set



8

PZS | PCS

REF	EAN 789.1114.	Embalaje Package		
		Un	kg	Largo x Ancho x Altura Length x Width x Height (mm)
41128/208	071870	6	5,04	275x330x125

Contenido | Set includes

8 Llaves combinadas: 10, 11, 12, 13, 14, 15, 17 y 19 mm. Embalaje plástica.

8 Combination wrenches 10, 11, 12, 13, 14, 15, 17 and 19 mm. Plastic roll pouch.

41128 Juego de Llaves Combinadas | Combination Wrench Set



5

PZS | PCS

REF	EAN 789.1114.	Embalaje Package		
		Un	kg	Largo x Ancho x Altura Length x Width x Height (mm)
41128/205	071887	6	2,49	265x220x115

Contenido | Set includes

5 Llaves combinadas: 10, 11, 12, 13 y 14 mm. Embalaje plástica.

5 Combination wrenches: 10, 11, 12, 13 and 14 mm. Plastic roll pouch.

41128 Juego de Llaves Combinadas | Combination Wrench Set

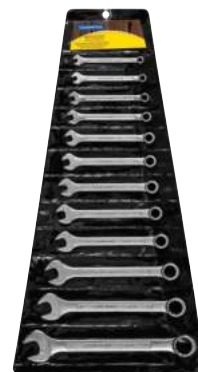

12

PZS | PCS

REF	EAN 789.1114.	Embalaje Package		
		Un	kg	Largo x Ancho x Altura Length x Width x Height (mm)
41128/212	094237	6	6,63	350x345x160

Contenido | Set includes

12 Llaves combinadas: 6, 7, 8, 9, 10, 11, 12, 13, 14, 17, 19 y 22 mm. Embalaje plástica.

12 C ombination wrenches: 6, 7, 8, 9, 10, 11, 12, 13, 14, 17, 19 and 22 mm. Plastic roll pouch.

41128 Juego de Llaves Combinadas | Combination Wrench Set

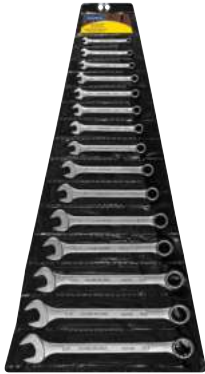

15
PZS | PCS

REF	EAN 789.1114.	Embalaje Package		
		Un	kg	Largo x Ancho x Altura Length x Width x Height (mm)
41128/215	094220	6	19,08	445x360x160

Contenido | Set includes

15 Llaves combinadas: 6, 7, 8, 10, 11, 12, 13, 14, 17, 19, 22, 24, 27, 30 y 32 mm. Embalaje plástica.

15 Combination wrenches: 6, 7, 8, 10, 11, 12, 13, 14, 17, 19, 22, 24, 27, 30 and 32 mm. Plastic roll pouch.

41128 Juego de Llaves Combinadas | Combination Wrench Set

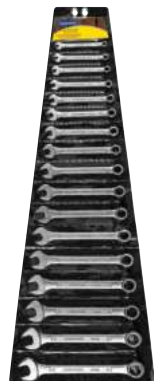

17
PZS | PCS

REF	EAN 789.1114.	Embalaje Package		
		Un	kg	Largo x Ancho x Altura Length x Width x Height (mm)
41128/217	094244	6	11,89	350x345x160

Contenido | Set includes

17 Llaves combinadas: 6, 7, 8, 9, 10, 11, 12, 13, 14, 15, 16, 17, 18, 19, 20, 21 y 22 mm; Embalaje plástica.

17 Combination wrenches: 6, 7, 8, 9, 10, 11, 12, 13, 14, 15, 16, 17, 18, 19, 20, 21 and 22 mm; Plastic roll pouch.

43409 Juego de Herramientas | Tool Set



4
PZS | PCS

REF	EAN 789.1114.	Embalaje Package		
		Un	kg	Largo x Ancho x Altura Length x Width x Height (mm)
43409/101	144031	6	4,55	410x215x150

Contenido | Set includes

1 Martillo de uña 20 mm; 1 Cortadora; 1 Pinza universal 7"; 1 Cinta métrica 2 m.

20 mm Claw hammer; Retractable knife; 7" Combination pliers; 2 m Measuring tape.

43409 Juego de Herramientas | Tool Set



11
PZS | PCS

REF	EAN 789.1114.	Embalaje Package		
		Un	kg	Largo x Ancho x Altura Length x Width x Height (mm)
43409/104	144062	6	6,69	395x360x155

Contenido | Set includes

1 Martillo de una 20 mm; 1 Pinza universal 7"; 3 Llaves fijas: 10x11, 12x13 y 14x15 mm; 2 Destornilladores punta chata: 1/8x3" y 3/16x3"; 2 Destornilladores punta cruzada 1/8x3" y 3/16x3"; 1 Cinta métrica 3 m; 1 Cortadora.

20 mm Claw hammer; 7" Combination pliers; 3 Open end wrenches: 10x11, 12x13 y 14x15 mm; 2 Slotted tip screwdrivers: 1/8x3" and 3/16x3"; 2 Cross recessed tip screwdrivers: 1/8x3" and 3/16x3"; 3 m Measuring tape; Retractable knife.

43409 Juego de Herramientas | Tool Set

28
PZS | PCS



REF	EAN 789.1114.	Embalaje Package		
		Un	kg	Largo x Ancho x Altura Length x Width x Height (mm)
43409/112	181432	6	4,78	380x305x55

Contenido | Set includes

Pistola de Cola; 9 Bastones de Cola Transparente; Cortadora; 10 Láminas para cortadora; 2 Destornilladores punta chata 1/8x3" y 3/16x3"; 2 Destornilladores punta cruzada 1/8x3" y 3/16x3"; Mini Destornillador; 1 Cinta métrica 2 m; 1 Pinza media caña 5".

Glue Gun; 9 Transparent Glue Sticks; Retractable Knife; 10 Retractable knife blades; 2 Slotted tip screwdrivers 1/8x3" and 3/16x3"; 2 Cross recessed tip screwdrivers 1/8x3" and 3/16x3"; Mini Screwdriver; 2 m Measuring tape; 5" Snipe nose pliers.

43409 Juego de Herramientas | Tool Set

14
PZS | PCS



REF	EAN 789.1114.	Embalaje Package		
		Un	kg	Largo x Ancho x Altura Length x Width x Height (mm)
43409/113	068979	6	4,65	380x310x40

Contenido | Set includes

Cortadora; 3 Destornilladores punta chata 1/8x3" y 3/16x3"; 3 Destornilladores punta cruzada 1/8x3" y 3/16x3"; 1 Cinta métrica 3 m; 1 Destornillador corto punta cruzada: 3/16x1.1/2"; 1 Destornillador corto punta chata: 3/16x1.1/2"; 4 Llaves fijas: 8x9, 10x11, 12x13, 14x15 mm.

Retractable Knife; 3 Slotted tip screwdrivers 1/8x3" and 3/16x3"; 3 Cross recessed tip screwdrivers 1/8x3" and 3/16x3"; 3 m Measuring tape; Cross recessed tip stubby type screwdriver: 3/16x1.1/2"; Cross recessed tip stubby type screwdriver: 3/16x1.1/2"; 4 Open end wrenches: 8x9, 10x11, 12x13, 14x15 mm.

43166 Cinta Métrica | Measuring Tape



REF	Tamaño Size	EAN 789.1114.	Embalaje Package		
			Un	kg	Largo x Ancho x Altura Length x Width x Height (mm)
43166/303	3 m	147469	12	1,46	265x160x110
43166/305	5 m	147476	12	2,45	270x185x120
43166/375	7,5 m	147483	12	4,35	320x190x130

43170 Escuadra | Square



REF	Tamaño Size	EAN 789.1114.	Embalaje Package		
			Un	kg	Largo x Ancho x Altura Length x Width x Height (mm)
43170/010	25 cm	013382	12	1,05	315x185x100
43170/012	30 cm	013399	12	1,18	380x155x115

43140 Nivel de Plástico | Plastic Level



REF	Tamaño Size	EAN 789.1114.	Embalaje Package		
			Un	kg	Largo x Ancho x Altura Length x Width x Height (mm)
43140/000	230 mm	027297	12	0,73	320x150x74

Características | Characteristics

Ampolla de 360° que permite lectura perfeccionada. Nivel con ampolla móvil - 3 posiciones diferentes (0°, 45° y 90°).

Calibrated reading 360° vial. Removable vial - 3 different positions (0°, 45° and 90°).

43757 Linterna 2AA | 2AA Plastic Flashlight



REF	EAN 789.1114.	Embalaje Package		
		Un	kg	Largo x Ancho x Altura Length x Width x Height (mm)
43757/300	088663	6	0,44	310x240x100

Características | Characteristics

Cuerpo inyectado en plástico recubierto de goma; 3 Lámparas de LED con voltaje de 3.2 - 4.5 V y amperaje de 0.02 - 0.04 A; Lente en policarbonato; Pilas no incluidas.

Injected body covered with rubber; 3 LED Lamps with 3.2 to 4.5 V tension and 0.02 to 0.04 A Current; Polycarbonate lens; Cells not included;

43757 Linterna 2D | 2D Plastic Flashlight



REF	EAN 789.1114.	Embalaje Package		
		Un	kg	Largo x Ancho x Altura Length x Width x Height (mm)
43757/301	088656	6	0,89	235x230x260

Características | Characteristics

Cuerpo inyectado en plástico recubierto de goma; 3 Lámparas de LED con voltaje de 3.2 - 4.5 V y Amperaje de 0.02 - 0.04 A; Lente en policarbonato; Pilas no incluidas.

Injected body covered with rubber; 3 LED Lamps with 3.2 to 4.5 V tension and 0.02 to 0.04 A current; Polycarbonate lens; Cells not included;

43752 Hierro de Soldadura | Welding Iron



REF	Potencia Power	Tensión Tension	EAN 789.1114.	Embalaje Package		
				Un	kg	Largo x Ancho x Altura Length x Width x Height (mm)
43752/502	25 W	127 V	047721	12	1,70	290x160x180
43752/503	25 W	220 V	047820	12	1,70	290x160x180
43752/504	40 W	127 V	053593	12	1,70	290x160x180
43752/505	40 W	220 V	053609	12	1,70	290x160x180
43752/506	70 W	127 V	053616	12	2,10	290x160x180
43752/507	70 W	220 V	053623	12	2,10	290x160x180

43760 Linterna | Flashlight



REF	EAN 789.1114.	Embalaje Package		
		Un	kg	Largo x Ancho x Altura Length x Width x Height (mm)
43760/300	088687	4	3,13	325x320x300

Características | Characteristics

Cuerpo en ABS reforzado resistente a impactos. Lámpara de criptón de 4,8 V - 0,75 A. Utiliza 1 batería de 6 V (no incluida) o 4 pilas "D" 1,5 V (no incluidas). Viene con adaptador para pilas. Resiste el agua, aceite y lubricantes. Propia para uso interno y externo: pesca, camping, náutica, etc.

Reinforced ABS body, impact resistant; 4.8 V - 0.75 A krypton lamp works with 6 V battery (not included) or 4 x 1.5 V "D" cells (not included). With battery adaptor. Water, oil and lubricant resistant. Proper to indoor and outdoor use: fishing, camping, navigation, etc.

CAJA SANFONADA PARA HERRAMIENTAS | CANTILEVER TOOL BOX

Para fácil almacenamiento y transporte de herramientas manuales y accesorios.
For easy storage and transportation of hand tools and accessories.

43800 Caja Porta Herramientas | Tool Box
3 Cajones | 3 Drawers



REF	EAN 789.1114.	Embalaje Package		
		Un	kg	Largo x Ancho x Altura Length x Width x Height (mm)
43800/004	175125	1	3,82	530x220x250

Características | Characteristics

Estructura en chapas de acero conformadas; posibilita el uso del candado; manijas fijas en la parte superior; pintura electrostática.

Conformed steel sheets structure; allows the use of padlock; fixed handles on top; electrostatic painting.

43800 Caja Porta Herramientas | Tool Box
7 Cajones | 7 Drawers



REF	EAN 789.1114.	Embalaje Package		
		Un	kg	Largo x Ancho x Altura Length x Width x Height (mm)
43800/007	178692	1	5,8	525x215x360

Características | Characteristics

Estructura en chapas de acero conformadas; posibilita el uso del candado; manijas fijas en la parte superior; pintura electrostática.

Conformed steel sheets structure; allows the use of padlock; fixed handles on top; electrostatic painting.

43800 Caja Porta Herramientas | Tool Box
5 Cajones | 5 Drawers

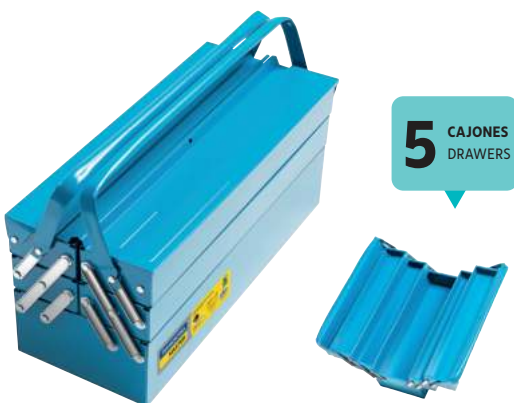

REF	EAN 789.1114.	Embalaje Package		
		Un	kg	Largo x Ancho x Altura Length x Width x Height (mm)
43800/005	164350	1	4,94	530x220x305

Características | Characteristics

Estructura en chapas de acero conformadas; posibilita el uso del candado; manijas fijas en la parte superior; pintura electrostática.

Conformed steel sheets structure; allows the use of padlock; fixed handles on top; electrostatic painting.



Todo en un
solo lugar
All in one place

41191 Maletín con Herramientas | Tool Case



41

PZS | PCS

REF	EAN 789.1114.	Embalaje Package		
		Un	kg	Largo x Ancho x Altura Length x Width x Height (mm)
41191/040	069174	3	5,17	385x225x205

Contenido | Set includes

Martillo de uña 18 mm; Pinza universal 7"; Cortadora; Cinta métrica 3 m; Destornillador con encastre de 1/4"; 10 Dados: 4, 5, 6, 7, 8, 9, 10, 11, 12, 13 mm; 25 punteras: 4 Puntas chatas 3, 4, 5, 6, 5 mm; 5 Puntas cruzadas nº 0, 1, 2, 3, 4; 5 Puntas hexagonales 2, 3, 4, 5, 6 mm; 6 Puntas trafox T10, T15, T20, T25, T30, T40; 5 Puntas pozidrive PZ0, PZ1, PZ2, PZ3, PZ4; Maletín plástico.

18 mm Claw hammer; 7" Combination pliers; Retractable knife; 3 m Measuring tape; Screwdriver with 1/4" square drive; 10 Sockets: 4, 5, 6, 7, 8, 9, 10, 11, 12, 13 mm; 25 tips: 4 slotted tips 3, 4, 5, 6, 5 mm; 5 cross recessed tips nº 0, 1, 2, 3, 4; 5 hexagonal tips 2, 3, 4, 5, 6 mm; 6 trafox tips T10, T15, T20, T25, T30, T40; 5 pozidrive tips PZ0, PZ1, PZ2, PZ3, PZ4; plastic case.

41191 Maletín con Herramientas | Tool Case



73

PZS | PCS

REF	EAN 789.1114.	Embalaje Package		
		Un	kg	Largo x Ancho x Altura Length x Width x Height (mm)
41191/073	152395	3	5,61	385x225x205

Contenido | Set includes

Tijera para coser; Martillo de uña 18 mm; Pinza universal 7"; 3 Llaves fijas: 8x9, 10x11, 12x13 mm; 2 Destornilladores punta chata: 1/8x3" y 3/16x4"; 2 Destornilladores punta cruzada: 1/8x3" y 3/16x4"; Cinta métrica 3 m; Linterna pequeña 2AA; 30 Buchas en nylon; 30 Tornillos para madera 4,2x50; Cinta aislante 5 m.

7" Sewing scissors; 18 mm Claw hammer; 7" Combination pliers; 3 Open end wrenches: 8x9, 10x11, 12x13 mm; 2 Slotted tip screwdrivers: 1/8x3" and 3/16x4"; 2 Cross recessed tip screwdrivers: 1/8x3" and 3/16x4"; 3 m Measuring tape; 2AA Flashlight; 30 Nylon rawl plugs; 30 4,2x50 Wood screws; Insulated tape 5 m.

41191 Maletín con Herramientas | Tool Case



65

PZS | PCS

REF	EAN 789.1114.	Embalaje Package		
		Un	kg	Largo x Ancho x Altura Length x Width x Height (mm)
41191/165	103120	3	10,77	475x370x240

Contenido | Set includes

Martillo de uña 20 mm; Pinza universal 7"; Pinza diagonal 4"; Pinza punta media caña 5"; Cortadora; Formón 3/8"; Mini arco de sierra; Cinta métrica 3 m; Nivel de plástico 230 mm; Mini destornillador; 5 Llaves fijas: 8x9, 10x11, 12x13, 14x15, 16x17 mm; 3 Destornilladores punta chata: 1/8x3", 3/16x5", 1/4x4"; 3 Destornilladores punta cruzada: NR 0 - 1/8x3", NR 1 - 3/16x3", NR 2 - 1/4x4"; 10 Láminas para cortadora; Linterna; Pistola de cola; 8 Bastones de cola; 6 Buchas; 6 Tornillos; 10 Clavos; Cinta aisladora; Cinta veda rosca; Maletín plástico.

20 mm Claw hammer; 7" Combination pliers; 4" Diagonal cutting pliers; 5" Snipe nose pliers; Retractable knife; 3/8" Wood chisel; Mini hacksaw; 3 m Measuring tape; 230 mm Plastic level; Mini screwdriver; 5 Open end wrenches: 8x9, 10x11, 12x13, 14x15, 16x17 mm; 3 Slotted tip screwdrivers: 1/8x3", 3/16x5", 1/4x4"; 3 Cross recessed tip screwdrivers: NR 0 - 1/8x3", NR 1 - 3/16x3", NR 2 - 1/4x4"; 10 Retractable knife blades; Flashlight; Glue gun; 8 Glue sticks; 6 Rawl plugs; 6 Screws; 10 Nails; Insulated tape; Thread sealing tape; Plastic case.

41192 Juego de Dados | Socket Set



24

PZS | PCS

REF	EAN 789.1114.	Embalaje Package		
		Un	kg	Largo x Ancho x Altura Length x Width x Height (mm)
41192/024	065534	6	3,10	290x130x225

Contenido | Set includes

10 Dados 4, 5, 6, 7, 8, 9, 10, 11, 12, 13 mm; Mango T 1/4"; Adaptador 1/4"; 12 Punteras: 3 Puntas chatas 4, 5, 5, 6, 5 mm; 3 Puntas cruzadas NR 1, NR 2, NR 3; 3 Puntas hexagonales 3, 4, 5 mm; 3 Puntas trafox T15, T20, T25.

10 Sockets 4, 5, 6, 7, 8, 9, 10, 11, 12, 13 mm; 1/4" T handle; 1/4" Adapter; 12 bits: 3 Slotted tips 4, 5, 5, 6, 5 mm; 3 Cross recessed tips NR 1, NR 2, NR 3; 3 Hexagonal tips 3, 4, 5 mm; 3 Trafox tips T15, T20, T25.

41905 Juego de Destornilladores de Precisión | Precision Screwdriver Set



6
PZS | PCS

REF	EAN 789.1114.	Embalaje Package		
		Un	kg	Largo x Ancho x Altura Length x Width x Height (mm)
41905/306	047738	12	1,41	220x210x150

Contenido | Set includes

4 Destornilladores de precisión punta chata 1.4, 2, 2.4, 3 mm;
2 Destornilladores de precisión punta cruzada NR 0, NR 1; Estuche plástico.

4 Slotted tip precision screwdrivers 1.4, 2, 2.4, 3 mm; 2 Cross recessed tip precision screwdrivers NR 0, NR 1; Plastic case.

42625 Juego de Sierras Copa para Madera | Wood Hole Saw Set

5
PZS | PCS



REF	EAN 789.1114.	Embalaje Package		
		Un	kg	Largo x Ancho x Altura Length x Width x Height (mm)
42625/501	133578	6	0,91	230x195x120

Contenido | Set includes

4 Sierras copa tamaños: 32, 38, 44 y 54 mm; 1 Soporte para sierra copa con broca piloto de 6x60 mm.

4 Hole saw sizes 32, 38, 44 and 54 mm; 1 Arbor with 6x60 mm pilot drill.

43145 Maletín con Brocas y Punteras | Drills and Bits Case



110
PZS | PCS



REF	EAN 789.1114.	Embalaje Package		
		Un	kg	Largo x Ancho x Altura Length x Width x Height (mm)
43145/110	110814	6	10,20	570x370x210

Contenido | Set includes

13 Brocas para acero: 1.5, 2, 2.5, 3, 3.2, 3.5, 4, 4.5, 4.8, 5, 5.5, 6 y 6.5 mm; 6 Brocas para madera: 4, 5, 6, 7, 8 y 10 mm; 3 Brocas para madera punta chata: 13,16 y 19 mm; 6 Brocas para concreto: 4, 5, 6, 7, 8 y 10 mm; 50 Punteras longitud 25 mm: 3 Punteras punta cruzada tipo pozidrive tamaños PZ1, PZ2 y PZ3; 6 Punteras punta trafix tamaños T10, T15, T20, T25, T27 y T30; 14 Punteras punta cruzada tamaños PH0, PH1, PH2 y PH3; 10 Punteras hexagonales tamaños 3, 4, 5, 6 y 7 mm; 3 Punteras cuadradas tamaños S1, S2 y S3; 14 Punteras punta chata tamaños 6, 8, 10 y 12 mm; 13 Punteras longitud 50 mm: 3 Punteras punta chata tamaños 6, 8 y 10 mm; 3 Punteras tipo trafix T10, T15 y T20; 7 Punteras tipo fenda cruzada tamaños PH1, PH2 y PH3; 10 Punteras tipo dado tamaños 4, 5, 6, 7, 8, 9, 10, 11, 12 y 13 mm; 3 escariadores; 1 Soporte magnético para punteras; Cinta métrica 2 m; 1 Mango con efecto matraca para las punteras; 2 Guías para punteras; Maletín plástico.

13 HSS drills sizes: 1.5, 2, 2.5, 3, 3.2, 3.5, 4, 4.5, 4.8, 5, 5.5, 6 and 6.5 mm; 6 Wood drills: 4, 5, 6, 7, 8 and 10 mm; 3 Flat wood drills: 13, 16 and 19 mm; 6 Masonry drills: 4, 5, 6, 7, 8 and 10 mm; 50 Pieces 25 mm length bits: 3 pozidrive cross recessed bits size PZ1, PZ2 and PZ3; 6 trafix bits sizes T10, T15, T20, T25, T27 and T30; 14 cross recessed bits sizes PH0, PH1, PH2 and PH3; 10 Hexagonal tips sizes 3, 4, 5, 6 and 7 mm; 3 square tips sizes S1, S2 and S3; 14 slotted bits sizes 6, 8, 10 and 12 mm; 13 Pieces 50 mm length bits: 3 slotted bits sizes 6, 8 and 10 mm; 3 trafix bits sizes T10, T15 and T20; 7 Cross recessed bits sizes PH1, PH2 and PH3; 10 Nut drives bits sizes 4, 5, 6, 7, 8, 9, 10, 11, 12 and 13 mm; 3 Reamers; 1 Magnetic bits holder; 2m Measuring tape; 1 Ratchet bits driver; 2 Finders; Blow mould case.

43270 Juego de Lápices para Carpintero | Carpenter Pencil Set



6
PZS | PCS

REF	EAN 789.1114.	Embalaje Package		
		Un	kg	Largo x Ancho x Altura Length x Width x Height (mm)
43270/306	118964	12	0,95	260x130x100



43272 Juego de Lápices para Carpintero | Carpenter Pencil Set



40
PZS | PCS

REF	EAN 789.1114.	Embalaje Package		
		Un	kg	Largo x Ancho x Altura Length x Width x Height (mm)
43272/900	131604	40	0,35	80x80x187

43408 Juego de Herramientas | Tool Set



4
PZS | PCS

REF	EAN 789.1114.	Embalaje Package		
		Un	kg	Largo x Ancho x Altura Length x Width x Height (mm)
43408/197	140835	12	1,78	230x200x100

Contenido | Set includes

1 Cortadora 130 mm; 1 Destornillador punta chata 3/16x3";
1 Destornillador punta cruzada 3/16x3"; 1 Cinta aislante 5 m.

130 mm Retractable knife; 3/16x3" Slotted tip screwdriver;
3/16x3" Cross recessed tip screwdriver; 5 m Insulated tape.

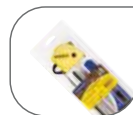

43408 Estuche con Dados y Punteras | Socket and Bits Set



REF	EAN 789.1114.	Embalaje Package		
		Un	kg	Largo x Ancho x Altura Length x Width x Height (mm)
43408/323	075618	12	3,97	310x290x210

Contenido | Set includes

1 Llave con encastre para adaptar punteras o dados; 1 adaptador para dados 1/4"; 1 Extension para punteras; 1 Estuche metálico con cremallera; 6 Dados sextavados 1/4": 5, 6, 7, 8, 9, 10 mm; 3 Punteras cruzadas: NR 1, NR 2, NR 3; 2 Punteras chatas: 5, 6,5 mm.

Screwdriver with plug to adapt bits and sockets; 1/4" Socket adapter; Extension for bits; Compact metal case with zipper; 6 1/4" Six points sockets: 5, 6, 7, 8, 9, 10 mm; 3 Cross recessed bits: NR 1, NR 2, NR 3; 2 Slotted tip bits: 5, 6,5 mm.

43408 Juego de Herramientas | Tool Set



REF	Voltaje Voltage	EAN 789.1114.	Embalaje Package		
			Un	kg	Largo x Ancho x Altura Length x Width x Height (mm)
43408/434	127 V	122169	2	6,90	505x490x160
43408/435	220 V	122176	2	6,90	505x490x160

Contenido | Set includes

1 Taladro de impacto 1/2" 500 W; 1 Martillo 18 mm; 1 Pinza universal 7"; 2 Destornilladores punta chata: 1/8x3" y 3/16x3"; 2 Destornilladores punta cruzada: 1/8x3" y 3/16x3"; 6 Brocas para cemento: 3, 4, 5, 6, 8 y 10 mm; 1 Cinta métrica 3 m; Cortadora; 30 taquetes (10 unidades de cada tamaño: 5, 6 y 8 mm); 30 Tornillos (10 unidades de cada tamaño: 3, 3,5, 5 mm); 25 Clavos; Molde plástico organizador de herramientas.

500 W 1/2" Impact drill; 18 mm Claw hammer; 7" Combination pliers; 2 Slotted tip screwdriver; 1/8x3" and 3/16x3"; 2 Cross recessed tip screwdrivers: 1/8x3" and 3/16x3"; 6 Masonry drills: 3, 4, 5, 6, 8 and 10 mm; 3 m Measuring tape; Retractable knife; 30 Plastic bushings (10 pieces of each size: 5, 6 and 8 mm); 30 Screws (10 units of each size: 3, 3,5 and 5 mm); 25 Nails; Plastic tool organizer.

43408 Juego de Brocas para Madera | Wood Drill Bit Set



REF	EAN 789.1114.	Embalaje Package		
		Un	kg	Largo x Ancho x Altura Length x Width x Height (mm)
43408/509	094084	12	0,90	180x95x120

Contenido | Set includes

4 Brocas para madera; tamaños 4, 5, 6 y 8 mm.

4 Wood drills; sizes 4, 5, 6 and 8 mm.

43408 Juego de Brocas para Cemento | Masonry Drill Bit Set



REF	EAN 789.1114.	Embalaje Package		
		Un	kg	Largo x Ancho x Altura Length x Width x Height (mm)
43408/510	094091	12	0,90	180x95x120

Contenido | Set includes

4 brocas para cemento; tamaños 4, 5, 6 y 8 mm.

4 masonry drills sizes; 4, 5, 6 and 8 mm.

43408 Juego de Brocas para Acero | HSS Drill Bit Set



REF	EAN 789.1114.	Embalaje Package		
		Un	kg	Largo x Ancho x Altura Length x Width x Height (mm)
43408/511	094107	12	0,97	335x110x70

Contenido | Set includes

5 Brocas para acero; tamaños 3, 4, 5, 6 y 8 mm.

5 HSS drills; sizes 3, 4, 5, 6 and 8 mm.

43408 Juego de Brocas Mix | Mix Drill Bit Set



9
PZS | PCS

REF	EAN	Embalaje Package		
		Un	kg	Largo x Ancho x Altura Length x Width x Height (mm)
43408/512	094114	12	2,40	225x200x122

Contenido | Set includes

3 Brocas para madera tamaños 5, 6 y 8 mm; 3 Brocas para cemento tamaños 5, 6 y 8 mm; 3 Brocas para acero tamaños 5, 6 y 8 mm.

3 Wood drill bits sizes 5, 6 and 8 mm; 3 Masonry drill bits sizes 5, 6 and 8 mm; 3 HSS Drill bits sizes 5, 6 and 8 mm.

43505 Juego de Tornillos y Taquetes | Screw and Plastic Bushings Set



100
PZS | PCS

REF	EAN	Embalaje Package		
		Un	kg	Largo x Ancho x Altura Length x Width x Height (mm)
43505/002	118940	12	2,47	235x155x185

Contenido | Set includes

20 Tornillos 3,5x25 mm; 15 Tornillos 4x30 mm; 15 Tornillos 5x38 mm; 20 Taquetes azules 5 mm; 15 Taquetes amarillos 6 mm; 15 Taquetes rojos 8 mm.

20 3,5x25 mm Screws; 15 4x30 mm Screws; 15 5x38 mm Screws; 20 Blue plastic bushings 5 mm; 15 Yellow plastic bushings 6 mm; 15 Red plastic bushings 8 mm.

43410 Maletín con Herramientas | Tool Case



30
PZS | PCS

REF	EAN	Embalaje Package		
		Un	kg	Largo x Ancho x Altura Length x Width x Height (mm)
43410/030	014594	3	12,25	475x370x240

Contenido | Set includes

1 Martillo de uña 20 mm; 1 Pinza pico loro 10"; 1 Pinza universal 6"; 1 Pinza corte diagonal 6" aislada 1000 V; 6 Destornilladores punta chata: 1/8x3", 1/8x6", 3/16x3", 3/16x5", 1/4x4", 1/4x6"; 1 Destornillador corto punta chata: 3/16x1.1/2"; 2 Destornilladores punta cruzada: NR 1 - 3/16x3", NR 2 -1/4x4"; 1 Destornillador corto punta cruzada: NR 1 - 3/16x1.1/2"; 1 Llave test; 1 Mini destornillador; 7 Llaves fijas: 6x7, 8x9, 10x11, 12x13, 14x15, 16x17, 18x19 mm; 1 Nivel de plástico 230 mm; 1 Escuadra 250 mm; 1 Cinta métrica 2 m; 1 Mini arco de sierra; 1 Formón 1/2"; 1 Cortadora; 1 Corta plumas; 6 Buchas; 6 Tornillos; 10 Clavos; Maletín plástico.

20 mm Claw hammer; 10" Water pump pliers; 6" Combination pliers; 6" 1000 V Insulated diagonal cutting pliers; 6 slotted tip screwdrivers: 1/8x3", 1/8x6", 3/16x3", 3/16x5", 1/4x4", 1/4x6"; slotted tip stubby type screwdriver: 3/16x1.1/2"; 2 cross recessed tip screwdrivers: NR 1 - 3/16x3", NR 2 -1/4x4"; cross recessed tip stubby type screwdriver: NR 1 - 3/16x1.1/2"; voltage tester; mini screwdriver; 7 open end wrenches: 6x7, 8x9, 10x11, 12x13, 14x15, 16x17, 18x19 mm; 230 mm plastic level; 250 mm square; 2 m measuring tape; mini hacksaw; 1/2" wood chisel; retractable knife; pocket knife; 6 rawl plugs; 6 screws; 10 nails; plastic case.

43505 Juego de Tornillos y Taquetes | Screw and Plastic Bushings Set



385
PZS | PCS

REF	EAN	Embalaje Package		
		Un	kg	Largo x Ancho x Altura Length x Width x Height (mm)
43505/003	118957	6	5,14	295x230x265

Contenido | Set includes

60 Tornillos 3x25 mm; 35 Tornillos 3,5x30 mm; 40 Tornillos 4x35 mm; 25 Tornillos 4x45 mm; 20 Tornillos 5x40 mm; 15 Tornillos 6x50 mm; 80 Taquetes gris 5 mm; 40 Taquetes Rojos 6 mm; 25 Taquetes amarillos 8 mm; 25 Taquetes verdes 8 mm; 20 Taquetes gris 10 mm; maletín plástico.

60 Screws 3x25 mm; 35 Screws 3,5x30 mm; 40 Screws 4x35 mm; 25 Screws 4x45 mm; 20 Screws 5x40 mm; 15 Screws 6x50 mm; 80 Gray plastic bushings 5 mm; 40 Red plastic bushings 6 mm; 25 Yellow plastic bushings 8 mm; 25 Green plastic bushings 8 mm; 20 Gray plastic bushings 10 mm; Plastic case.

43804 Organizador de Plástico 7.1/2" con Divisores | 7.1/2" Plastic Organizer with Dividers



REF	EAN 789.1114.	Embalaje Package		
		Un	kg	Largo x Ancho x Altura Length x Width x Height (mm)
43804/001	159882	6	1,66	405x210x155

Características | Characteristics

Cuerpo inyectado en plástico de alta resistencia. Posee 6 compartimentos para el almacenamiento de pequeñas piezas. Puede ser almacenado dentro de las cajas plásticas Tramontina Master 43803/020 y 43804/020. Volumen total: 1,27 L.

High resistance plastic injected body. It has 6 compartments for storing small parts. It can be stored inside Tramontina Master 43804/017 and 43804/020 plastic boxes. Total volume: 1.27 L.

43804 Organizador de Plástico 16" con Divisores | 16" Plastic Organizer with Dividers

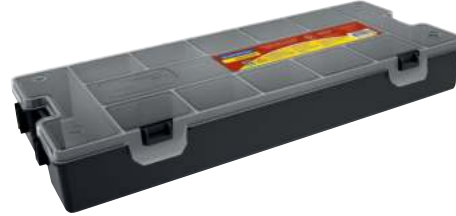

REF	EAN 789.1114.	Embalaje Package		
		Un	kg	Largo x Ancho x Altura Length x Width x Height (mm)
43804/002	151756	1	0,58	425x185x70

Características | Characteristics

Cuerpo inyectado en plástico de alta resistencia. Posee 13 compartimentos para el almacenamiento de pequeñas piezas. Puede ser almacenado dentro de la caja plástica Tramontina Master 43804/017. Capacidad: 3 kg.

High resistance plastic injected body. It has 13 compartments for storing small parts. It can be stored inside Tramontina Master 43804/017 plastic box. Load capacity: 3 kg.

43802 Caja Plástica con Tapa Organizadora 20" | 20" Plastic Box with Organizer Cover



REF	EAN 789.1114.	Embalaje Package		
		Un	kg	Largo x Ancho x Altura Length x Width x Height (mm)
43802/020	162349	1	2,33	515x265x245

Características | Characteristics

Cuerpo inyectado en plástico de alta resistencia. Posee tapa organizadora con 11 divisorias. Dos cerraduras plásticas.

High resistance plastic injected body. It has an organizer cover with 11 partitions. Two plastic locks.

43804 Caja Plástica para Herramientas 13" | 13" Plastic Tool Box



REF	EAN 789.1114.	Embalaje Package		
		Un	kg	Largo x Ancho x Altura Length x Width x Height (mm)
43804/013	159516	1	0,84	340x182x157

Características | Characteristics

Cuerpo inyectado en plástico de alta resistencia. Cerradura de plástico. Posee bandeja plástica interna removible.

High resistance plastic injected body. Plastic lock. It has a removable internal plastic tray.

Todas cajas plásticas poseen pasador de acero para reforzar la bisagra de la tapa.

All plastic boxes have a steel pin to reinforce the articulation of the lid.



43804 Caja Plástica para Herramientas 17" |
17" Plastic Tool Box



REF	EAN 789.1114.	Embalaje Package		
		Un	kg	Largo x Ancho x Altura Length x Width x Height (mm)
43804/017	151749	1	0,84	445x220x200

Características | Characteristics

Cuerpo inyectado en plástico de alta resistencia. Cerradura de plástico. Posee bandeja plástica interna removible.

High resistance plastic injected body. Plastic lock. It has a removable internal plastic tray.

43804 Caja Plástica para Herramientas 17" |
17" Plastic Tool Box



REF	EAN 789.1114.	Embalaje Package		
		Un	kg	Largo x Ancho x Altura Length x Width x Height (mm)
43804/117	153996	1	4,90	625x440x385

Características | Characteristics

Cuerpo inyectado en plástico de alta resistencia. Cerradura de plástico.

High resistance plastic injected body. Plastic lock.

43804 Caja Plástica para Herramientas 17" |
17" Plastic Tool Box



REF	EAN 789.1114.	Embalaje Package		
		Un	kg	Largo x Ancho x Altura Length x Width x Height (mm)
43804/217	154009	1	1,47	445x220x200

Características | Characteristics

Cuerpo inyectado en plástico de alta resistencia. Cerradura de plástico. Acompaña organizador de plástico 16".

High resistance plastic injected body. Plastic lock. With 16" plastic organizer.

43804 Caja Plástica para Herramientas 20" |
20" Plastic Tool Box



REF	EAN 789.1114.	Embalaje Package		
		Un	kg	Largo x Ancho x Altura Length x Width x Height (mm)
43804/020	159523	1	1,90	515x265x245

Características | Characteristics

Cuerpo inyectado en plástico de alta resistencia. Dos cerraduras de plástico. Posee bandeja plástica interna removible.

High resistance plastic injected body. Two plastic locks. It has a removable internal plastic tray.



EMBALAJE DE EXHIBICIÓN PARA CAJAS DE PLÁSTICO DISPLAY PACKAGING FOR PLASTIC BOXES

43803 Caja Plástica con Tapa Organizadora 13" |
13" Plastic Box with Organizer Cover



REF	EAN 789.1114.	Embalaje Package	
		Un	Largo x Ancho x Altura Length x Width x Height (mm)
43803/013	143959	108	1,050x880x770

43804 Caja Plástica con Tapa Organizadora 13" |
13" Plastic Box with Organizer Cover



REF	EAN 789.1114.	Embalaje Package	
		Un	Largo x Ancho x Altura Length x Width x Height (mm)
43804/013	143973	108	1,050x880x770

43803 Caja Plástica con Tapa Organizadora 17" |
17" Plastic Box with Organizer Cover



REF	EAN 789.1114.	Embalaje Package	
		Un	Largo x Ancho x Altura Length x Width x Height (mm)
43803/017	143966	40	1,050x920x800

43803 Caja Plástica con Tapa Organizadora 17" |
17" Plastic Box with Organizer Cover



REF	EAN 789.1114.	Embalaje Package	
		Un	Largo x Ancho x Altura Length x Width x Height (mm)
43803/017	143966	40	1,050x920x800

43803 Caja Plástica con Tapa Organizadora 20" |
20" Plastic Box with Organizer Cover



REF	EAN 789.1114.	Embalaje Package	
		Un	Largo x Ancho x Altura Length x Width x Height (mm)
43803/020	143973	24	1,070x1,070x740

43803 Caja Plástica con Tapa Organizadora 20" |
20" Plastic Box with Organizer Cover



REF	EAN 789.1114.	Embalaje Package	
		Un	Largo x Ancho x Altura Length x Width x Height (mm)
43803/020	143973	24	1,070x1,070x740

43805 Maletín Organizador Plástico 17" |
17" Plastic Organizer Case



REF	EAN 789.1114.	Embalaje Package		
		Un	kg	Largo x Ancho x Altura Length x Width x Height (mm)
43805/017	152937	1	1,47	455x355x90

Características | Characteristics

Cuerpo inyectado en plástico de alta resistencia. Cuatro trabas para cierre seguro. Con 14 divisorias móviles.

High resistance plastic injected body. Plastic lock. Four latches for secure closing. With 14 mobile dividers.

43805 Maletín Organizador Plástico 17" |
17" Plastic Organizer Case



REF	EAN 789.1114.	Embalaje Package		
		Un	kg	Largo x Ancho x Altura Length x Width x Height (mm)
43805/015	164947	1	2,04	455x355x90

Características | Characteristics

Cuerpo inyectado en plástico de alta resistencia. Cuatro trabas para cierre seguro. Con 8 divisorias móviles, 6 módulos dobles y 5 módulos simples.

High resistance plastic injected body. Plastic lock. Four latches for secure closing. With 8 mobile dividers, 6 double organizer units and 5 single organizer units.



Todo ordenado y siempre a LA MANO!

Everything organized and always AT HAND!



43756 Bastón de Cola Transparente | Transparent Glue Stick



REF	EAN 789.1114.	Embalaje Package		
		Un	kg	Largo x Ancho x Altura Length x Width x Height (mm)
43756/311	152685	12	0,45	160x115x60
43756/341	152692	12	0,70	160x115x80

Contenido | Set includes

43756/311 - 9 Bastones de cola 7x100 mm. | 9 7x100 mm Glue sticks.
43756/341 - 6 Bastones de cola 11x100 mm. | 6 11x100 mm Glue sticks.

43756 Bastón de Cola Transparente | Transparent Glue Stick



REF	EAN 789.1114.	Embalaje Package		
		Un	kg	Largo x Ancho x Altura Length x Width x Height (mm)
43756/321	152708	12	6,20	325x325x115
43756/351	152715	12	6,20	325x325x115

Contenido | Set includes

43756/321 - Bastones de cola 7x300 mm. | 7x300 mm Glue stick pack - 500 g.
43756/351 - Bastones de cola 11x300 mm | 11x300 mm Glue stick pack - 500 g.

43755 Pistola de Cola | Glue Gun



REF	Potencia Power	EAN 789.1114.	Embalaje Package		
			Un	kg	Largo x Ancho x Altura Length x Width x Height (mm)
43755/510	10-12 W	015386	6	1,07	400x210x110
43755/530	20-25 W	049473	12	3,48	470x270x175

Características | Characteristics

Mango inyectado en plástico. Punta metálica. Doble voltage automático. Con 2 bastones de cola.

Plastic injected body. Metal tip. Automatic bi-volt system. With 2 glue sticks.



42329 Esponja de Limpieza | Tire Dressing
Applicator Sponges

2
PZS | PCS

REF	EAN 789.1114.	Embalaje Package		
		Un	kg	Largo x Ancho x Altura Length x Width x Height (mm)
42329/001	162608	12	0,84	300x255x290

Características | Characteristics

Esponjas aplicadoras de silicona y negro. Base reforzada para mejor manejo. 1 Pieza con perfil redondeado. 1 Pieza con perfil recto.

Silicone and black tire dressing applicator sponges. Reinforced base for better handling. 1 Rounded applicator. 1 Straight applicator.



42331 Esponja de Limpieza | Cleaning Sponje

REF	EAN 789.1114.	Embalaje Package		
		Un	kg	Largo x Ancho x Altura Length x Width x Height (mm)
42331/001	158687	12	0,64	370x215x250

Características | Characteristics

Ideal para limpieza interna y externa de automóvil, motonetas, bicicletas, etc. Producida en poliuretano, material blando, limpia sin rascar.

Ideal to external and internal cleaning on cars, cleaning motorbike, bike and so on. Produced in polyurethane, soft material, clean without scratch.



42332 Esponja de Microfibra para Limpieza |
Microfiber Cleaning Sponje

REF	EAN 789.1114.	Embalaje Package		
		Un	kg	Largo x Ancho x Altura Length x Width x Height (mm)
42332/001	158694	12	1,17	260x260x385

Características | Characteristics

Ideal para limpieza interna y externa de automóvil, motonetas, bicicletas, etc. Puede ser utilizada para limpiar, secar y pulir. Absorbe hasta 8 veces más agua que las esponjas convencionales. Material blando, limpia sin rascar y sin soltar pelusas.

Ideal to external and internal cleaning on cars, cleaning motorbike, bike and so on. Can be used to clean, dry and polish. Absorb up to 8 times more water than a common sponge. Soft material, clean without scratch and release lint.

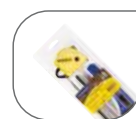

42333 Esponja Doble Cara | Double Sided Sponge

REF	EAN	Embalaje Package		
		Un	kg	Largo x Ancho x Altura Length x Width x Height (mm)
42333/001	159202	12	0,47	210x200x140

Características | Characteristics

Ideal para limpieza detallada de automóvil, motonetas, bicicletas, etc. Material blando, limpia sin rascar y sin soltar pelusas; puede ser utilizada para aplicación de cera, silicón o pastas de limpieza; 2 en 1: posee un lado en microfibra y otro en gamuza sintética.

Ideal to detailed cleaning on cars, cleaning motorbike, bike and so on. Soft material, clean without scratch and release lint; can be used to wax, silicon, and cleaning pastes applications; 2 in 1, it has one microfiber side and one synthetic suede side.



42334 Guante de Microfibras | Microfiber Sleeve

REF	EAN	Embalaje Package		
		Un	kg	Largo x Ancho x Altura Length x Width x Height (mm)
42334/001	157598	12	1,63	265x180x260

Características | Characteristics

Ideal para limpiezas en general, limpieza interna y externa de automóvil, motonetas, bicicletas, etc. Puede ser utilizada para limpiar, secar y pulir. Material blando, limpia superficies delicadas sin rascar y sin soltar pelusas. Utilizada para limpieza de superficies irregulares e sitios de difícil acceso. Posee dupla camada (lado liso y lado con cerdas).

Ideal to general cleaning, external and internal cleaning on cars, cleaning motorbike, bike and so on. Can be used to clean, dry and polish. Soft material, clean without scratch and release lint. Used to clean delicate surfaces and hard to reach places. Double layer (smooth side and bristles side).



42335 Guante de Camuza para Limpieza | Suede Cleaning Sleeve

REF	EAN	Embalaje Package		
		Un	kg	Largo x Ancho x Altura Length x Width x Height (mm)
42335/001	158106	12	1,28	310x185x255

Características | Characteristics

Ideal para limpieza interna y externa de automóvil, motonetas, bicicletas, etc. Puede ser utilizada para limpiar, secar y pulir. Material blando, limpia sin rascar y sin soltar pelusas. Producida en camuza sintética que auxilia en la retención de espuma para una limpieza más eficiente.

Ideal to external and internal cleaning on cars, cleaning motorbike, bike and so on. Can be used to clean, dry and polish. Soft material, clean without scratch and release lint. Produced with synthetic suede that assist in the retention of foam for a more efficient washing.

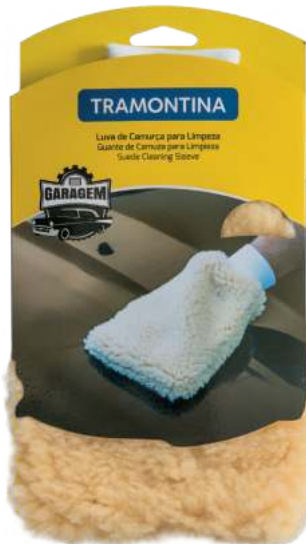

42337 Toalla Multiuso | Multipurpose Cloth

REF	EAN 789.1114.	Embalaje Package		
		Un	kg	Largo x Ancho x Altura Lenght x Width x Height (mm)
42337/001	159233	12	2,70	310x210x278

Características | Characteristics

Excelente poder de absorción y retención de líquidos, puede guardar hasta 10 veces más líquidos do que una toalla convencional; puede ser utilizada para secar cualquier superficie.

Excellent dry power can dry up to 10 times more water than a normal towel; can be used to dry any kind of surface.



42336 Paños de Microfibra | Microfiber Cloth

REF	PZAS PCS	EAN 789.1114.	Embalaje Package		
			Un	kg	Largo x Ancho x Altura Lenght x Width x Height (mm)
42336/002	2	159219	12	1,35	450x160x130
42336/003	3	159226	12	1,90	450x160x200

Características | Characteristics

Ideal para limpiezas en general, limpieza interna y externa de automóvil, motonetas, bicicletas, etc. Puede ser utilizada para limpiar, secar y pulir; material blando, limpia superficies delicadas sin riscar y sin soltar pelusas; kit con dos o tres piezas.

Ideal to general cleanings, external and internal cleaning on cars, cleaning motorbike, bike and so on; can be used to clean, dry and polish; soft material, clean delicate surfaces without scratch and release lint; kit with two or three pieces.



42338 Cepillo para Limpieza de Ruedas | Wheel Cleaning Brush

REF	EAN 789.1114.	Embalaje Package		
		Un	kg	Largo x Ancho x Altura Lenght x Width x Height (mm)
42338/001	159776	12	1,97	250x190x340

Características | Characteristics

Escoba con cerdas blandas, ideal para limpieza de rodas y neumáticos. Puede ser utilizada en coches, motos, bicicletas, etc.

Soft bristles brush, ideal to wheel and tires cleanings. Can be used with cars, motorbikes, bikes and so on.



43785 Tapa Sol Universal con Superficie Reflectante | Universal Sunshade with Reflective Surface

REF	EAN 789.1114.	Embalaje Package			
		Un	kg	Largo x Ancho x Altura Length x Width x Height (mm)	
43785/001	159769	12	2,19	620x150x385	

Características | Characteristics

Diseñado para proteger el interior del coche contra la incidencia de rayos solares. Posee superficie reflectante y efecto térmico disminuyendo el calor en el interior del coche después de la exposición al sol. Tamaño universal adaptable a la mayoría de los coches. Viene con dos ventosas para fijación en el cristal del coche. Producto plegable y fácil de guardar.

Designed to protect the interior of the car against the incidence of sunrays. It has reflective surface and thermal effect, reducing the heat inside the car after exposure to the sun. Universal size, can be used with most cars. Two glass suction cups included. Foldable and easy to store product.

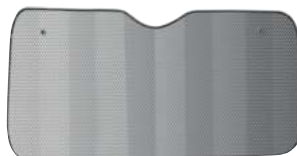

43785 Parasol Retráctil Automovilístico | Retractable Sunshade for Cars

REF	EAN 789.1114.	Embalaje Package			
		Un	kg	Largo x Ancho x Altura Length x Width x Height (mm)	
43785/002	162622	12	3,20	480x240x180	

Características | Characteristics

Parasol retráctil automovilístico para vidrios laterales. Tamaño: 36x45 cm. Fijado con ventosas o presilla. Posee botón de accionamiento para retracción de la cortina.

Automotive retractable sunshade for side windows. Size: 36x45 cm. Mounted with suction cups or clips. Activating button for retraction of shade.



43791 Protector de Impact para Garaje | Impact Garage Wall Protector

REF	EAN 789.1114.	Embalaje Package			
		Un	kg	Largo x Ancho x Altura Length x Width x Height (mm)	
43791/001	163391	12	2,29	510x290x210	

Características | Characteristics

Producido en doble capa de EVA. Acompaña 2 tornillos y tacos. Flechas de señal para mejor visualización. Tamaño: 45,5 x 8,5 x 3,8 cm; Fijado por tornillos/tacos y cinta adhesiva.

Produced in double layer EVA. Includes 2 screws and wall plugs. Direction arrows for better visualization. Size: 45,5 x 8,5 x 3,8 cm. Mounted with screws/wall plugs and scotch tape.



43786 Juego de Alfombras para Automóviles | Carpet Mat Set for Automobiles



REF	EAN 789.1114.	Embalaje Package		
		Un	kg	Largo x Ancho x Altura Length x Width x Height (mm)
43786/001	159752	6	12,93	750x510x115

Características | Characteristics

Acabamiento de alta calidad y costuras resistentes. Tamaño universal, encaja en la mayoría de los coches. Verso antiadherente. Tamaño alfombras frontales: 70x48 cm. Tamaño alfombras traseras: 40x45 cm.

High quality finishing and strong dressmaking. Universal size, fit in the most part of cars. Non-stick back. Front carpet size: 70x48 cm. Back carpet size: 40x45 cm.



43786 Juego de Alfombras de Goma para Automóviles | Rubber Floor Mat Set for Automobiles



REF	EAN 789.1114.	Embalaje Package		
		Un	kg	Largo x Ancho x Altura Length x Width x Height (mm)
43786/010	162639	6	24,70	800x560x140

Características | Characteristics

Tamaño universal. Se adecua a varios modelos de vehículos, con marcas especiales para corte y ajuste de tamaño. Textura antideslizante. Tamaño alfombras frontales: 76x48 cm. Tamaño alfombras traseras: 43,5x48 mm.

Universal size. Adaptable for various car models, with special markings to cut and adjust the size. Non-skid texture. Front carpet size: 76x48 cm. Back carpet size: 43,5x48 mm.

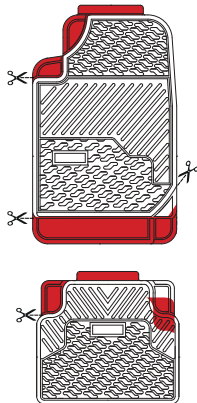

43786 Juego de Alfombras de Goma para Camionetas y SUVs | Rubber Floor Mat Set for Pickup Trucks and SUVs



REF	EAN 789.1114.	Embalaje Package		
		Un	kg	Largo x Ancho x Altura Length x Width x Height (mm)
43786/011	162646	6	27,76	800x560x140

Características | Characteristics

Tamaño universal. Se adecua a varios modelos de vehículos, con marcas especiales para corte y ajuste de tamaño. Textura antideslizante. Tamaño alfombras frontales: 71x50,5 cm. Tamaño alfombras traseras: 40,5x50,5 mm.

Universal size. Adaptable for various car models, with special markings to cut and adjust the size. Non-skid texture. Front carpet size: 71x50,5 cm. Back carpet size: 40,5x50,5 mm.

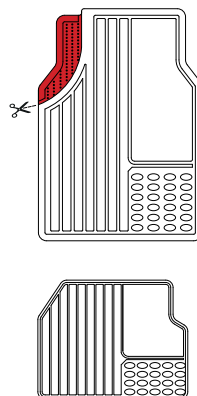

43789 Candado Cable de Acero con Llave para Llanta de Repuesto | Steel Cable Lock with Key - For Steppe

REF	EAN 789.1114.	Embalaje Package		
		Un	kg	Largo x Ancho x Altura Lenght x Width x Height (mm)
43789/002	174717	6	6,00	480x220x140

Características | Characteristics

Acompaña 2 llaves. Posee 20 mm de diámetro. 1,2 metros largo. Tapa de protección contra polvo. Producto flexible, permite detener lo candado en locales variados. Para uso en automóviles, camionetas y SUVs.

2 keys included. Diameter: 20 mm. 1.2 meters long. With special cover to protect against dust. Flexible product, allows holding the lock in many places. Use for automobiles, pickup trucks and SUVs.



43789 Candado Antirrobo con Llave | Anti-theft Lock with Key

REF	EAN 789.1114.	Embalaje Package		
		Un	kg	Largo x Ancho x Altura Lenght x Width x Height (mm)
43789/001	158113	12	3,26	130x190x320

Características | Characteristics

Viene con 2 llaves. Posee 1,2 metros largo. Tapa de protección contra polvo. Producto flexible, permite detener lo candado en locales variados. Para uso en motocicletas.

2 keys included. 1.2 meters long. With special cover to protect against dust. Flexible product, allows holding the lock in many places. Use for motorcycles.



43787 Traba Antirrobo para Volante | Anti-theft Lock for Steering Wheel

REF	EAN 789.1114.	Embalaje Package		
		Un	kg	Largo x Ancho x Altura Lenght x Width x Height (mm)
43787/001	158120	12	9,70	625x290x140

Características | Characteristics

Producido en acero carbono. Revestimiento de goma para proteger el volante y pedalera. Viene con 2 llaves. Producto ajustable, permite adaptar a los más diversos coches. Regulación máxima de longitud: 725 mm. Regulación mínima de longitud: 510 mm.

Produced in carbon steel. Rubber grip to protect the steering wheel and pedal. 2 included keys. Adjustable product, can be used with most cars. Maximum length adjustment: 725 mm. Minimum length adjustment: 510 mm.



43782 Cubierta para Motocicletas | Waterproof Motorcycle Cover

REF	Tamaño Size (cm)	EAN 789.1114.	Embalaje Package		
			Un	kg	Largo x Ancho x Altura Length x Width x Height (mm)
43782/001	P - 183x89x119	124989	2	1,10	325x205x150
43782/003	G - 229x99x125	124996	2	1,30	320x210x150

TABLA DE TAMAÑOS | SIZE TABLE:

HONDA	TAMAÑO SIZE	YAMAHA	TAMAÑO SIZE	SUZUKI	TAMAÑO SIZE	KASINSKI	TAMAÑO SIZE
BIZ 100	P	Factor YBR 125	P	Burgman	P	Comet 150	P
BIZ 125	P	Factor YBR 125 Pro	P	Burgman 400	P	CRZ 150	P
CG 125 Cargo	P	Factor Black Edition	P	GS 120	P	CRZ 150 SM	P
CG 125 Fan	P	T 115 Crypton	P	GSR 125	P	Mirage 150	P
CG 150 Fan	P	XTZ 125	P	GSR 125S	P	Prima 150	P
CG 150 Titan	P	XTZ 125 X	P	GSR 150I	P	Prima 500	P
Lead 110	P			GSR SE	P	Prima Electra	P
NXR 125 Bros	P	Fazer 150	G	Intruder 125ED	P	Soft 50	P
NXR 150 Bros	P	Fazer Y 250	G	YES SE	P	Win elektra	P
Pop 100	P	Fazer Black Edition	G			Win 110	P
		Fazer 250 BlueFlex	G				
CB 300R	G	Lander XTZ 250	G	Bandit 650	G	Comet GT 250	G
CB 500F	G	TMAX	G	Bandit 650S	G	Comet GT 250R	G
CB 500X	G	XJ6 F	G	Bandit 1250	G	Comet GT 650	G
CB 600F Hornet	G	XJ6 N	G	Bandit 1250S	G	Commet GT	G
CBR 500R	G	XJ6 N SP	G	Burgman 650	G	650R	G
NX 400I Falcon	G	XT 660 R	G	B-King	G	Mirage 250	G
PCX	G	XTZ 250 Ténéré	G	Gladius	G	Mirage 650	G
XRE 300	G	XT 660Z Ténéré	G	GSR 750/A	G		
		XT 1200Z Super Ténéré	G	GSX650F	G		
		YZF-R1	G	GSX1250FA	G		
				Inazuma	G		
				V-Strom 1000	G		
				V-Strom 650	G		



Protección contra | Protection against:



43780 Cubierta para Automóviles | Waterproof Car Cover

REF	Tamaño Size (cm)	EAN 789.1114.	Embalaje Package		
			Un	kg	Largo x Ancho x Altura Length x Width x Height (mm)
43780/001	P - 406x119x165	124958	2	5,10	470x370x270
43780/002	M - 483x119x178	124965	2	5,50	470x370x270
43780/003	G - 533x119x178	124972	2	5,80	470x370x270

TABLA DE TAMAÑOS | SIZE TABLE:

Tamaño Size	Ford	Fiat	Volkswagen	Chevrolet	Otros Others
P Automóviles hasta Vehicles up to : 4,7 m 	KA Fiesta Hatch	Mobi Palio Uno	Fusca Gol Upl	Celta Agile Corsa	Citroen C3 HB20 Hatch Kwid Etios Hatch Peugeot 206
M Automóviles hasta Vehicles up to : 4,7 m 	Focus Escort Fiesta KA Sedan New Fiesta	Argo Brava Cronos Idea Punto Siena Stilo Strada Temptra Tipo	Bora Fox Golf Logus Parati Saveiro Polo Virtus Voyage	Astra Corsa Sedan Kadett Montana Meriva Prisma Onix Onix Sedan	Audi A3 Logan Clio Sedan Megane Peugeot 208 HB20 Sedan Honda City Peugeot 307 Sanderó Yaris
G Automóviles hasta Vehicles up to : 5,2 m 	Fusion	Línea Palio Weekend	Jetta Passat Quantum Space Fox	Caravan Cruze Omega Opala Vectra	Civic Corolla



- Posee forro interno que proporciona protección total a la pintura del automóvil.
- With inner lining, giving total protection for the car paint.

43783 **Rejilla Elástica para Motos |**
Motorcycle Elastic Grid

REF	EAN 789.1114.	Embalaje Package		
		Un	kg	Largo x Ancho x Altura Length x Width x Height (mm)
43783/001	159790	12	2,66	275x260x150

Características | Characteristics

Ideal para fijación de cascos y cargas ligeras en bagajero de la motocicleta. Posee 6 ganchos plásticos para mayor estabilidad. Producida con elástico de alta calidad que proporciona mayor durabilidad. Tamaño: 350x350 mm.

Ideal for securing light loads and helmets in the rack of motorbike. It has 6 plastic hooks for greater stability. Produced with high quality elastic that provides greater durability. Size: 350x350 mm.



43784 **Cordón Elástico con Ganchos Plásticos |**
Elastic Cord with Plastic Hooks

REF	PZAS PCS	EAN 789.1114.	Embalaje Package		
			Un	kg	Largo x Ancho x Altura Length x Width x Height (mm)
43784/001	1	162660	12	1,85	260x140x335
43784/003	3	162677	12	4,59	430x185x320

Características | Characteristics

Longitud: 1,5 m. Elástico con diámetro de 7 mm. Ganchos plásticos.

Length: 1.5 m. Elastic diameter: 7 mm. Plastic hooks.



43781 **Rejilla Elástica para Fijación de Carga |**
Elastic Grid to Cargo Fixation

REF	Tamaño Size (cm)	Ganchos Hooks	EAN 789.1114.	Embalaje Package		
				Un	kg	Largo x Ancho x Altura Length x Width x Height (mm)
43781/001	90x70	12	159806	12	8,58	270x355x360

Características | Characteristics

Ideal para fijación de cargas ligeras en el maletero de los coches y SUVs. Producida con elástico de alta calidad que proporciona mayor durabilidad.

Ideal for securing light loads in the trunk of cars. Produced with high quality elastic that provides greater durability.



43781 **Rejilla Elástica para Fijación de Carga |**
Elastic Grid to Cargo Fixation

REF	Tamaño Size (cm)	Ganchos Hooks	EAN 789.1114.	Embalaje Package		
				Un	kg	Largo x Ancho x Altura Length x Width x Height (mm)
43781/002	170x130	22	159813	12	21,40	320x395x470

Características | Characteristics

Ideal para fijación de cargas ligeras en el maletero de los coches y SUVs. Producida con elástico de alta calidad que proporciona mayor durabilidad.

Ideal for securing light loads in the trunk of cars. Produced with high quality elastic that provides greater durability.



42339 Cargador para Coche | Car Charger

REF	EAN 789.1114.	Embalaje Package		
		Un	kg	Largo x Ancho x Altura Lenght x Width x Height (mm)
42339/001	159783	12	0,50	320x170x90

Características | Characteristics

Convierte 24 V y 12 V para 5 V. Posee una corriente eléctrica de 2000 mAh. Posee LED indicador de carga.

Convert 24 V and 12 V to 5 V. 2000mAh electrical current. It has LED to indicate the charger mode.



42340 Soporte para Celula/Smartphone | Cell Phone/Smartphone Holder

REF	EAN 789.1114.	Embalaje Package		
		Un	kg	Largo x Ancho x Altura Lenght x Width x Height (mm)
42340/001	162615	12	1,18	230x230x150

Características | Characteristics

Posee garra ajustable con capacidad de 6 a 8,6 cm. Base giratoria 360°. Garras forradas de goma. Fijado a la salida de aire de los automóviles.

Holder with adjustable arm with capacity from 6 a 8,6 cm. 360° rotating base. Rubberized arms. Mounted at the car's air vent.



42340 Soporte Multiuso Vehicular | Multiuse Car Support

REF	EAN 789.1114.	Embalaje Package		
		Un	kg	Largo x Ancho x Altura Lenght x Width x Height (mm)
42340/002	163407	12	3,46	330x300x420

Características | Characteristics

Fabricado en plástico ABS, goma y metal. Eje flexible. Base giratoria 360°. Base revestida de goma con garras ajustables. Capacidad: 5,5 - 8,5 cm. Fijado con ventosa.

Produced in ABS plastic, rubber and metal. Flexible spindle. 360° swivel base. Rubber coated base with adjustable claw. Capacity: 5.5 - 8.5 cm. Mounted with a suction cup.



43215 Cable de Auxilio para Arranque 250 A | 250 A Booster Cables

REF	EAN 789.1114.	Embalaje Package		
		Un	kg	Largo x Ancho x Altura Length x Width x Height (mm)
43215/002	159240	12	8,76	465x300x230

Características | Characteristics

Cables de cobre de 8 mm de diámetro recubiertos con PVC. Pinzas de cobre tipo cocodrilo recubiertas en PVC. Capacidad: 250 A. Longitud: 2,5 m

8 mm Diameter cooper cables covered with PVC. Crocodile cooper connectors covered with PVC. Capacity: 250 A. Length: 2.5 m

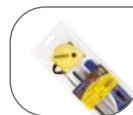

43215 Cable de Auxilio para Arranque 300 A | 300 A Booster Cables

REF	EAN 789.1114.	Embalaje Package		
		Un	kg	Largo x Ancho x Altura Length x Width x Height (mm)
43215/003	119985	6	7,64	310x310x320

Características | Characteristics

Cables de cobre de 9 mm de diámetro recubiertos con PVC. Pinzas de cobre tipo cocodrilo recubiertas en TPR. Capacidad: 300 A. Longitud: 3 m.

9 mm diameter cooper cables covered with PVC. Crocodile cooper connectors covered with TPR. Capacity: 300 A. Length: 3 m.



42341 Medidor Digital de Presión para Neumáticos | Digital Tire Pressure Gauge

REF	EAN 789.1114.	Embalaje Package		
		Un	kg	Largo x Ancho x Altura Length x Width x Height (mm)
42341/001	162691	12	0,86	180x180x130

Características | Characteristics

Cuerpo fabricado en plástico de alta resistencia. Capacidad: 0 a 700 kPa / 0 a 100 psi. Precisión: +/- 1 psi. 4 unidades de medida - psi, bar, kPa y kg/cm². Visor y boquilla con luz para una mejor visualización. Acompaña 4 pilas tipo LR 44. Utilizado en válvulas convencionales (tipo americana / Schrader).

Produced with high resistance plastic. Capacity: 0 to 700 kPa / 0 to 100 psi. Accuracy: +/- 1 psi. 4 units of measurement - psi, bar, kPa e kg/cm². Lighted display and nozzle for better viewing. 4 LR 44 batteries included. Used in conventional valves (American type).



42330 Compresor de Aire Portátil | Portable Air Compressor | 50 W - 12 V - 300 psi - 8 l/min.

REF	EAN 789.1114.	Embalaje Package		
		Un	kg	Largo x Ancho x Altura Length x Width x Height (mm)
42330/001	124941	6	4,11	370x310x260

Contenido | Set includes

Puntera adaptadora para inflar pelotas; 2 punteras adaptadoras para inflar flotadores; manual de instrucciones.

Adapter tip to inflate balls; 2 adapter tips to inflate pool floats; instructions manual.



42350 Aspiradora para Auto 70 W - 12 V |
70 W - 12 V Car Vacuum Cleaner

REF	EAN 789.1114.	Embalaje Package		
		Un	kg	Largo x Ancho x Altura Length x Width x Height (mm)
42350/070	093902	6	5,34	410x240x390

Contenido | Set includes

1 Bocal con cepillos y 1 boca para grietas.

Extension nozzle and brush.



42345 Aspiradora para Auto 60 W - 12 V |
60 W - 12 V Car Vacuum Cleaner

REF	EAN 789.1114.	Embalaje Package		
		Un	kg	Largo x Ancho x Altura Length x Width x Height (mm)
42345/060	144468	6	4,47	370x370x200



43411 Juego de Herramientas | Tool Set

9

PZS | PCS

REF	EAN 789.1114.	Embalaje Package		
		Un	kg	Largo x Ancho x Altura Length x Width x Height (mm)
43411/910	102758	1	1,40	382x225x205

Contenido | Set includes

1 Pinza universal 7"; 2 Destornilladores punta chata: 1/8x3" y 3/16x4"; 1 Destornillador punta cruzada 3/16x4"; 3 Llaves fijas: 8x9, 10x11, 12x13 mm; 1 Cortadora; 1 Aspiradora para auto 70 W; bolsa.

1 7" Combination pliers; 2 Slotted tip screwdrivers: 1/8x3" and 3/16x4"; 1 3/16x4" Cross recessed tip screwdriver; 3 Open end wrenches: 8x9, 10x11, 12x13 mm; 1 Retractable knife; 1 70 W Car vacuum cleaner; Bag.



43411 Juego de Herramientas | Tool Set

3

PZS | PCS

REF	EAN 789.1114.	Embalaje Package		
		Un	kg	Largo x Ancho x Altura Length x Width x Height (mm)
43411/901	154368	1	2,69	406x365x168

Contenido | Set includes

1 Aspiradora para auto 60 W - 12 V; 1 Compresor de aire portátil 50 W - 12 V; 1 Cable de auxilio para arranque; 1 Estuche para el almacenaje de herramientas hecho en goma EVA.

1 60 W - 12 V Car vacuum cleaner; 1 50 W - 12 V Portable air compressor; 1 300 A booster cables; 1 Case produced in EVA.



43411 Juego de Herramientas | Tool Set

2

PZS | PCS

REF	EAN 789.1114.	Embalaje Package		
		Un	kg	Largo x Ancho x Altura Length x Width x Height (mm)
43411/902	154382	1	2,04	406x365x168

Contenido | Set includes

1 Aspiradora para auto 60 W - 12 V; 1 Compresor de aire portátil 50 W - 12 V; 1 Estuche para el almacenaje de herramientas hecho en goma EVA.

1 60 W - 12 V Car vacuum cleaner; 1 12 V - 50 W Portable air compressor for cars; 1 Case produced in EVA.



43411 Juego de Herramientas | Tool Set

9
PZS | PCS

REF	EAN 789.1114.	Embalaje Package		
		Un	kg	Largo x Ancho x Altura Length x Width x Height (mm)
43411/903	154405	1	2,04	406x365x168

Contenido | Set includes

1 Aspiradora para auto 60 W - 12 V; 1 Compresor de aire portátil 50 W - 12 V; 1 Pinza universal 7"; 1 Cortadora; 3 Llaves fijas: 10x11, 12x13, 14x15 mm; 1 Destornillador punta chata 3/16x3"; 1 Destornillador punta cruzada 3/16x3"; 1 Estuche para el almacenaje de herramientas hecho en goma EVA.

1 60 W - 12 V Car vacuum cleaner; 1 50 W - 12 V Portable air compressor for cars; 1 7" Combination pliers; 1 Knife retractable; 3 Open end wrenches: 10x11, 12x13, 14x15 mm; 1 3/16x3" Slotted tip screwdriver; 1 3/16x3" Cross recessed tip screwdriver; 1 Case produced in EVA.

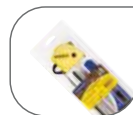

43411 Juego de Herramientas | Tool Set

8
PZS | PCS

REF	EAN 789.1114.	Embalaje Package		
		Un	kg	Largo x Ancho x Altura Length x Width x Height (mm)
43411/904	154429	1	1,45	406x365x168

Contenido | Set includes

1 Aspiradora para auto 60 W - 12 V; 1 Pinza universal 7"; 1 Cortadora; 3 Llaves fijas: 10x11, 12x13, 14x15 mm; 1 Destornillador punta chata 3/16x3"; 1 Destornillador punta cruzada 3/16x3"; 1 Estuche para el almacenaje de herramientas hecho en goma EVA.

1 60 W - 12 V Car vacuum cleaner; 1 7" Combination pliers; 1 Retractable knife; 3 Open end wrenches: 10x11, 12x13, 14x15 mm; 1 3/16x3" Slotted tip screwdriver; 1 3/16x3" Cross recessed tip screwdriver; 1 Case produced in EVA.



42808 Juego de Llaves de Pipa para Moto |
Motorcycle Hollow Offset Set



3
PZS | PCS

REF	EAN 789.1114.	Embalaje Package		
		Un	kg	Largo x Ancho x Altura Length x Width x Height (mm)
42808/103	110999	12	5,12	285x235x90

Contenido | Set includes

3 Llaves pipa abierta: 8, 10 y 12 mm.

3 Hollow offset pipe wrenches: 8, 10 and 12 mm.

42808 Juego de Llaves de Pipa para Moto |
Motorcycle Hollow Offset Set



3
PZS | PCS

REF	EAN 789.1114.	Embalaje Package		
		Un	kg	Largo x Ancho x Altura Length x Width x Height (mm)
42808/503	110852	12	6,35	255x225x245

Contenido | Set includes

3 Llaves pipa abierta: 8, 10 y 12 mm. Embalaje plástica.

3 Hollow offset pipe wrenches: 8, 10 and 12 mm. Plastic packaging.

42860 Llave en Cruz con Espátula |
4 Way Cross Wrench with Chisel



REF	EAN 789.1114.	Embalaje Package		
		Un	kg	Largo x Ancho x Altura Length x Width x Height (mm)
42860/001	015959	6	7,06	345x345x185

Características | Characteristics

Tamaño: 17-19-21 mm + espátula.

Size: 17-19-21 mm + chisel.

42830 Llave en "L" para Rueda |
"L" Type Wrench



REF	EAN 789.1114.	Embalaje Package		
		Un	kg	Largo x Ancho x Altura Length x Width x Height (mm)
42830/917	067224	12	4,28	320x150x74
42830/919	067231	12	4,30	320x150x74

43134 Juego de Herramientas para Bicicletas | Bike Tool Kit

17
PZS | PCS



Embalaje | Package

REF	EAN	Un	kg	Largo x Ancho x Altura Length x Width x Height (mm)
43134/101	789.1114.141085	12	3,45	300x260x160

Contenido | Set includes

5 Llaves estriadas: 9, 10, 12, 13 y 15 mm; 3 Llaves de rayos: 12,13 y 14 GE; 6 Llaves hexagonales: 2, 2.5, 3, 4, 5 y 6 mm; 1 Destornillador punta chata; 1 Destornillador punta cruzada; 1 Destornillador de tuerca tubular 8 mm.

5 Ring spanners: 9, 10, 12, 13 and 15 mm; 3 Spoke wrenches: 12, 13 and 14 GE; 6 Hexagonal keys: 2, 2.5, 3, 4, 5 and 6 mm; 1 Slotted tip screwdriver; 1 Cross recessed tip screwdriver; 1 8 mm Nut driver.



43132 Inflador Manual | Manual Air Pump | 160 psi - 11 bar

Longitud Máxima del Bombeo | Maximum Pumping Length

600 mm

Diámetro del Tubo | Tube Diameter

32 mm

Embalaje | Package

REF	EAN 789.1114.	Un	kg	Largo x Ancho x Altura Length x Width x Height (mm)
43132/001	124927	2	2,08	620x280x145

Contenido | Set includes

1 Puntera adaptadora para inflar pelotas, 1 Puntera adaptadora para inflar flotadores, 1 Adaptador para inflar cámaras con boquilla tipo Presta (fina), Acoplada a la válvula de fijación.

1 adapter tip to inflate balls, 1 adapter tip to inflate pool floats, 1 adapter to inflate bike tyres with Presta nozzle (light), attached to the fixing valve.



43132 Bomba de Aire Portátil para Bicicleta | Portable Bike Air Pump - 90 psi - 6 bar

Embalaje | Package

REF	EAN 789.1114.	Un	kg	Largo x Ancho x Altura Length x Width x Height (mm)
43132/002	159707	12	2,52	330x195x135

Contenido | Set includes

Puede ser utilizada en válvulas con puntera fina (Presta) e válvulas convencionales (Americanas). Acompaña soporte y tornillos M5x150 mm para fijación en la bicicleta.

It can be used with slim tips valves (Presta type) and normal valves (American type). Includes special support and M5x150 mm screws for fixation.



43132 Bomba de Aire Manual con Manómetro | Portable Bike Air Pump with Manometer

Embalaje | Package

REF	EAN 789.1114.	Un	kg	Largo x Ancho x Altura Length x Width x Height (mm)
43132/004	175431	12	2,31	335x285x160

Contenido | Set includes

Capacidad de 100 psi - 7 bar. Puede ser utilizada en válvulas con puntera fina (Presta) e válvulas convencionales (Americanas). Acompaña dos tornillos para fijación en la bicicleta.

Capacity of 100 psi - 7 bar. It can be used with slim tips valves (Presta type) and normal valves (American type). Includes two screws for fixation on the bike frame.

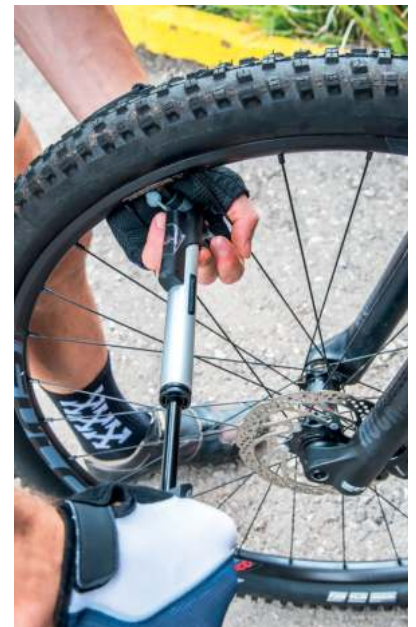

43210 Linterna de LED Recargable para Bicicleta | LED Rechargeable Bike Flashlight

REF	EAN 789.1114.	Embalaje Package		
		Un	kg	Largo x Ancho x Altura Length x Width x Height (mm)
43210/001	159721	12	2,80	380x160x230

Características | Characteristics

Batería recargable de Li-Po. Acompaña cargador USB. Posee 4 fases de operación (iluminación alta, mediana, baja y señalizador). Luminosidad: 200 lumens.

Li-Po rechargeable battery. Includes USB charger. 4 working stages (high, medium, low and wigwag). Luminosity: 200 lumens.

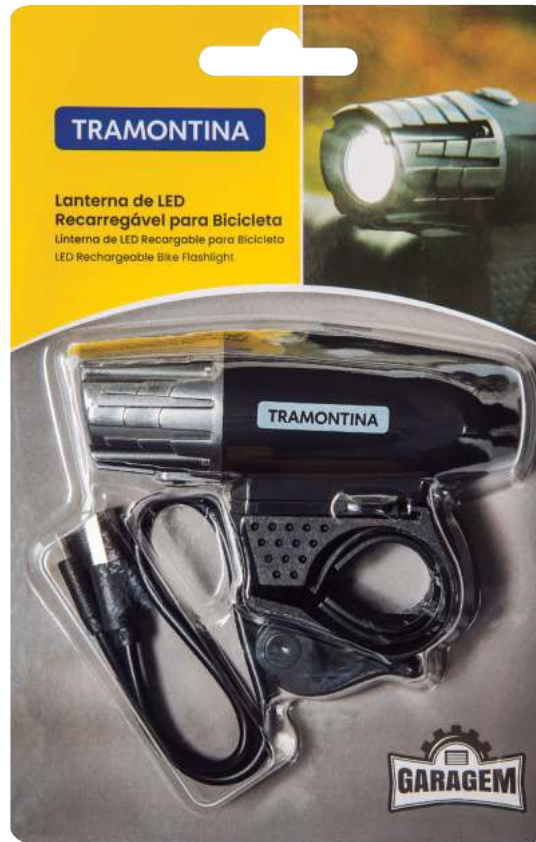

43210 Señalizador Trasero de LED para Bicicleta | LED Bike Wigwag

REF	EAN 789.1114.	Embalaje Package		
		Un	kg	Largo x Ancho x Altura Length x Width x Height (mm)
43210/003	159745	12	0,90	285x215x130

Características | Characteristics

Posee soporte plástico para fijación en el asiento. Señalizador de seguridad - Leds en color rojo. Posee 3 fases de operación (2 Leds piscando, 1 Led piscando y 2 Leds accesos).

Includes seat support. Safety wigwag - Red color LED. With 3 working stages (2 flashing Leds, 1 flashing Leds and 2 continuous ON Leds).



43213 Guantes para Ciclismo | Bike Gloves

REF	Tamaño Size	EAN 789.1114.	Embalaje Package		
			Un	kg	Largo x Ancho x Altura Length x Width x Height (mm)
43213/001	P	157000	12	0,84	210x165x245
43213/002	M	157017	12	0,86	210x165x245
43213/003	G	157021	12	0,86	210x165x245

Características | Characteristics

Guantes para ciclismo unisex con estofado para las manos. Cierre con velcro. Modelo de dedo corto. Producida en poliéster, elastina y PU.

Unisex gloves with upholstered. Velcro closing. Short finger model. Produced in polyester, elastane and PU.



43211 Botella de Hidratación 750 ml |
750 ml Hydration Bottle

REF	EAN	Embalaje Package		
		Un	kg	Largo x Ancho x Altura Length x Width x Height (mm)
43211/001	789.1114.158656	12	1,16	240x240x310

Características | Characteristics

Modelo unisex, inyectado en polímero de alta densidad. Puntura abre fácil y tapa removible.

Unisex model, injected in high-density polymer. Easy open spout and removable cover.



43218 Soporte de Botella para Bicicleta |
Bike Bottle Support

REF	EAN	Embalaje Package		
		Un	kg	Largo x Ancho x Altura Length x Width x Height (mm)
43218/001	789.1114.158663	12	0,97	320x320x200

Características | Characteristics

Viene con dos tornillos M5 de acero inoxidable. Ideal para botellas hasta 75 mm de diámetro. Modelo unisex, inyectado en polímero de alta densidad.

2 M5 stainless steel included. Ideal to bottles until 75 mm diameter. Unisex model, injected in high-density polymer.



43212 Candado para Bicicleta con Llave |
Bike Lock with Key

REF	EAN 789.1114.	Embalaje Package		
		Un	kg	Largo x Ancho x Altura Length x Width x Height (mm)
43212/001	157567	12	3,27	380x150x190

Características | Characteristics

Producido con cable de acero e revestimiento de PVC. Acompaña 2 llaves. Tapa de protección contra polvo. Posee 1 metro largo.

Produced with steel cables and PVC cover. 2 keys included. With special cover to protect against dust. 1 meter long.



43212 Candado para Bicicleta con Segreto |
Bicycle Lock with Combination

REF	EAN 789.1114.	Embalaje Package		
		Un	kg	Largo x Ancho x Altura Length x Width x Height (mm)
43212/002	162684	12	4,26	280x150x180

Características | Characteristics

Tamaño: 12 x 1200 mm. Combinación de 5 dígitos.

Size: 12 x 1200 mm. 5-Digit combination.



43219 Soporte de Pared Horizontal para Bicicleta | Horizontal Bicycle Wall-Mounted Rack

REF	EAN	Embalaje Package		
		Un	kg	Largo x Ancho x Altura Length x Width x Height (mm)
43219/001	789.1114.158670	12	12,31	510x365x400

Características | Characteristics

Apoyos emborrachados que evitan arañazos en el cuadro. Acompaña tornillos e bujes para instalación. Capacidad de carga: 20 kg.

Rubber supports to avoid damages in the frame. Screws and bushings included. Load capacity: 20 kg.



Dispositivo imantado para mantener el soporte recogido cuando está sin la bicicleta. |

Magnetic device to keep the support collected when it is out of the bike.

43219 Soporte de Pared Vertical para Bicicleta | Vertical Bicycle Wall-Mounted Rack

REF	EAN	Embalaje Package		
		Un	kg	Largo x Ancho x Altura Length x Width x Height (mm)
43219/002	789.1114.162653	12	6,28	490x230x280

Características | Characteristics

Estructura de chapa de acero. Color negro. Acompaña 4 tornillos y tacos de fijación. Brazo revestido de goma.

Steel plate body. Black color. Includes 4 screws and wall plugs for mounting. Bracket with rubber coating.

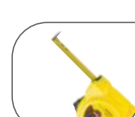
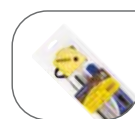

43216 Bolsa de Cuadro para Bicicleta |
Bike Frame Bag

REF	Tamaño Size (mm)	EAN 789.1114.	Embalaje Package		
			Un	kg	Largo x Ancho x Altura Lenght x Width x Height (mm)
43216/001	230x200x60	157574	12	1,25	280x180x245

Características | Characteristics

Posee bandas reflectantes para mayor seguridad del ciclista.
3 puntos de fijación con velcro. Cierre metálico. Capacidad de 1,4 litros.

It has reflective bands to security; 3 velcro fixing points. Metal clasp. 1.4 L capacity.



43216 Bolsa de Sillín para Bicicleta |
Saddle Frame Bag

REF	Tamaño Size (mm)	EAN 789.1114.	Embalaje Package		
			Un	kg	Largo x Ancho x Altura Lenght x Width x Height (mm)
43216/002	175x115x110	157581	12	2,80	380x340x180

Características | Characteristics

Posee banda reflectante para mayor seguridad del ciclista. Acompaña soporte y tornillos para fijación en el sillín de la bicicleta. Posee extensor para aumentar el volumen interno. Capacidad de 1,0 litros.

It has reflective bands to security. Seat support and screws included. Special extender to increase the bag size. 1.0 L capacity.



43217 Bolsa de Bicicleta para Celular |
Mobile Bike Bag

REF	Tamaño Size (mm)	EAN 789.1114.	Embalaje Package		
			Un	kg	Largo x Ancho x Altura Lenght x Width x Height (mm)
43217/001	200x95x50	158137	12	2,00	320x220x340

Características | Characteristics

Posee banda reflectante para mayor seguridad del ciclista.
2 puntos de fijación con velcro + presilla elástica. Cierre metálico. Posee visor para celular hasta 5,5" e salida para audífono. Capacidad de 0,95 litros.

It has reflective bands to security. 2 velcro fixing points + elastic clip. Metal clasp. 5.5" mobile viewer and earphone output. 0.95 L capacity.



71900 Exhibidor Línea Garaje |
Garage Line Display

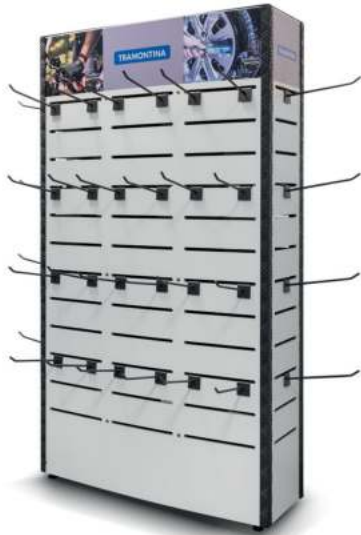

REF	EAN 789.8434.	Embalaje Package		
		Un	kg	Largo x Ancho x Altura Length x Width x Height (mm)
71900/138	092820	1	58,00	370x900x1550

71900 Exhibidor Línea Garaje |
Garage Line Display



REF	EAN 789.8434.	Embalaje Package		
		Un	kg	Largo x Ancho x Altura Length x Width x Height (mm)
71900/781	092837	1	51,00	320x730x1920



71900 Exhidor de Cartón | Carton Display



REF	EAN 789.8434.	Embalaje Package		
		Un	kg	Largo x Ancho x Altura Length x Width x Height (mm)
71900/586	090789	1	5,00	980x730x60



**Tramontina Africa (PTY) LTD (TRAF)**

Longpoint, Cnr. Witkoppen & Montecasino Blvd, Ext. 42, Fourways 2055, Joanesburgo - South Africa - Tel.:27 (11) 300 9500

**Tramontina Germany GmbH (TGERMANY)**

Kamekestr, 21, 50672, Colônia - Alemania | Germany - Tel.: 49 (221) 7789 991-0

**Tramontina Saudi Arabia**

Commercial Complex, Office No. 11 Al-Kharj Road - Al-Musfah District, Riyadh 7818 - 14525, Saudi Arabia. Contact: info.tksa@tramontina.com

**Marketing & Sales PTY LTD (TRAS)**

Unit. 7, 167 Prospect Highway Seven Hills, NSW 2147. Australia - Phone +61 2 9674 1799

**Tramontina Canada (TCAN)**

8 Prologis Blvd, Suite #101, Mississauga, Ontario, L5W 0B3, Canada - Tel.: +1 (905) 670 5200

**Tramontina de Chile S.A. (TCHILE)**

Av. Andrés Bello 2233, Piso 4, Comuna de Prodigencia, Santiago - Chile - Tel.: 56 (2) 2676 5000

**TUSA-HK LTD Guangzhou Representative Office**

17E, City Development Building 189, Tiyuxi Road, Tianhe Guangzhou, Guangdong 510620 - China - Tel.: 86 (20) 3879 9702

**Tramontina de Colombia S A S (TECOL)**

Km 1,5 Vía Siberia, Parque Empresarial Arcos de Cota Manzana B Bodega 4 y 5, Potrero Chico - Cota (Cundinamarca) Bogotá - Colombia - Tel.: 57 (1) 623 4500

**Tramontina UAE LLC (TDUBAI)**

Tameem House, 5th Floor, Off. 501/502, Al-Barsha Heights, P.O. Box 28924 - Dubai - UAE - Tel.: 971 (4) 450 4301 | 4302

**Tramontina del Ecuador S.A. (TECUADOR)**

Parque Empresarial Colón Edificio Pacific Plaza Piso 1 - Oficina 103 - Guayaquil - Ecuador - Tel.: 593 (4) 454 1794 - 593 (4) 461 2435

**Tramontina España (TIBERICA)**

Calle Santa Engracia 90, Piso 5, 28010, Madrid, España - Tel.: +34 915 76 78 30

**Tramontina USA, Inc. (TUSA)**

12955 West Airport Boulevard Sugar Land, Texas 77478-6119 - USA - Tel.: 1 (281) 340 8400

**Tramontina França (TFRANCE)**

3 rue Pierre Gilles de Gennes, Bat A, Salle 2B, 45000, Orléans - Tel.: +33 745485872

**Tramontina Riga (TRIGA)**

Vienības gatve 109, office 5.3 LV-1058, Riga, Latvia - Tel.: 371 6730 4958

**Tramontina Malaysia (TMALAYSIA)**

Level 32, Menara Prestige, No. 1, Jalan Pinang, Kuala Lumpur - 50450, Malaysia - Tel.: +603 2728 1164

**Tramontina de Mexico S.A. de C.V. (TEMEX)**

Av. de la Palma, N° 8, Torre Acqua - piso 1, Col. San Fernando la Herradura (Interlomas), Huixquilucan - Edo.de Mexico, C.P. 52787, Mexico - Tel.: 52 (55) 5950 0470

**Tramontina Pakistan**

Office 10-A, Potohar Plaza, Fazal e Haq Road, Blue Area, Islamabad, Pakistan Tel.: (92) 512120698

**Tramontina de Panamá S.A. (TCARIBE)**

Av. Samuel Lewis y Calle 55, Obarrio, edificio SL 55, Planta Baja Banco Panamá, Piso 14, Oficina 14-2, Ciudad de Panamá - Tel.: 507 309 9507 - 507 309 9508 - 507 309 9509

**Tramontina del Peru S.A.C. (TPERU)**

Av. Javier Prado, N° 496, Torre Las Orquídeas, Oficina 1002, San Isidro, Lima - 27, Peru - Tel.: 51 (1) 421 2135 - 51 (1) 422 7580

**Tramontina United Kingdom LTD. (TUK)**

411, Cannon Wharf Business Centre Pell Street Surrey Quays SE8 5EN, London- England - Tel.: +44 (0) 20 31 76 4558

**Tramontina Singapore PTE LTD. (TRASING)**

9 Harrison Road, Level 6, S36951 - Singapore - Tel.: 65 6635 6264

**Tramontina Uruguay (TURUGUAY)**

Av. Dr. Luís A. De Herrera, 1248, WTC (World Trade Center), Torre 3, Piso 2, Oficina 263, 11.300, Montevideo, Uruguay - Tel.: +598 96 125 576

Imagen de los productos | Products images:

- Algunas imágenes presentadas en este catálogo son meramente ilustrativas.
- Some pictures presented in this catalogue are merely illustrative.

Modificaciones en los productos | Changes to products

Tramontina reserva el derecho de modificar cualquier producto presente en este catálogo, con el objetivo de mejorarlo o siempre que existan razones técnicas o comerciales para eso. Cualquier alteración que sea efectivada está exenta de aviso previo y no obliga la reposición de las unidades ya vendidas.

Tramontina reserves the right to change items presented in this catalogue, with the purpose of improvement based on technical or commercial feedback. These change are exempt of advance notice and do necessitate the replacement of the units already sold.

Retiro o discontinuación de productos | Cancellation or discontinued items:

Tramontina reserva el derecho de retirar de producción o anular la comercialización de cualquier producto presente en este catálogo.

Tramontina reserves the right to take out of production or cancel the commercialization of any items presented in this catalogue.

Measurements and weights | Medidas y pesos:

Los valores relativos a pesos y medidas contenidos en este catálogo están sujetos a modificaciones.

The values related to weight and measurements presented in this catalogue are subject to change.

Garantía | Warranty:

- Los productos Tramontina poseen garantía total contra defectos de fabricación.
- Esa garantía considera la substitución o reparo sin costo de los artículos con defecto.

- La garantía no considera:
 - Problemas resultantes del consumo normal del producto;
 - Utilización incorrecta del producto;
 - Modificación de las características de construcción del producto.

La restitución de los artículos defectuosos debe ser analizada junto al distribuidor o, directamente con la fábrica, dependiendo del caso, y deberá ser exigida mediante la factura de compra.

- All Tramontina products have total warranty against deficiency in material or workmanship.
- This warranty allows the replacement or repair free of charge of the defective product.

- The warranty doesn't cover:
 - Problems resulted from products' normal usage;
 - Misuse of the product;
 - Change to the products characteristics.

The replacement of the damaged products will be analyzed along with the distributor or directly at the factory, depending on the situation, the presentation of a purchase invoice will be necessary.

The values related to weight and measurements presented in this catalogue are subject to change.





TRAMONTINA

TRAMONTINA GARIBALDI S.A. IND. MET.

Rua Tramontina, 600 | CEP 95720-000
Garibaldi | RS | Brasil
CNPJ 90.049.792/0001-81
Indústria Brasileira

